



**DOMESTIC PHOTOVOLTAIC  
FIELD TRIALS**

**Final Technical Report**

**CONTRACT NUMBER: S/P2/00305 and  
S/P2/00409**

**URN NUMBER: 06/2218**

The DTI drives our ambition of 'prosperity for all' by working to create the best environment for business success in the UK. We help people and companies become more productive by promoting enterprise, innovation and creativity.

We champion UK business at home and abroad. We invest heavily in world-class science and technology. We protect the rights of working people and consumers. And we stand for fair and open markets in the UK, Europe and the world.

**PV DOMESTIC FIELD TRIAL  
FINAL TECHNICAL REPORT**

ETSU S/P2/00305/00/00  
and S/P2/00409/00/00

**Contractor  
BRE**

M Munzinger  
F Crick  
E.J. Dayan  
N Pearsall (NPAC)  
C Martin (EMC)

The work described in this report was carried out under contract as part of the DTI New and Renewable Energy Programme, which is managed by Future Energy Solutions. The views and judgements expressed in this report are those of the contractor and do not necessarily reflect those of the DTI or Future Energy Solutions.

First Published 2006  
© Crown Copyright 2006

**dti**

## Executive summary

The UK Photovoltaic Domestic Field Trial (PV DFT) is the first wide spread monitoring of PV systems in domestic buildings in the UK. Groups of domestic buildings were monitored through all phases of design, building integration, commissioning, and operation. This has allowed information to be collected on buildability, reliability, maintainability and PV performance under real UK climate and operating conditions.

The aims and objectives are summarised in section 1.

The PV DFT involved a very wide range of systems and applications which are summarised in sections 2 and 3. These include:

- 28 different projects installing PV systems on a wide variety of domestic buildings
- 20 new-build sites, 13 retrofit, and 2 projects with both new-build and retrofit (note that some projects had more than one PV cluster across separate locations, i.e. forming different sites).
- 14 sites installed roof-integrated systems and 17 sites opted for roof-mounted systems. Two sites also installed bespoke systems integrated into the façade and/or roof.
- Installations included roof-integrated tiles, modules and laminates as well as retrofitted systems on flat roofs and bespoke systems
- 474 individual PV systems installed in 217 private and public dwellings
- a total of 742kWp installed capacity

The PVDFT programme has collected extensive data from across the country providing important and detailed information on system design, installation, performance and reliability. This has been used to refine the guidelines for monitoring work, to improve the design of PV systems, to develop best practice guidelines, and to provide a basis for recommendations.

The programme thereby informs the building and electricity sectors about the suitability of the technology. It has also provided accessible examples of a wide range of domestic PV installations for both the general public and the planning authorities. It has also identified barriers to the uptake of PV and has set out recommendations for removing these. Internationally, the IEA PVPS programme (<http://www.iea-pvps.org>) is adding the results to its database of PV systems across the globe.

Good Practice Guidelines have been produced based on the lessons that have been learnt from all stages of the design, construction and PV installation. These lessons have been loosely grouped into three categories: communication, site/location and good practice. The key general issues are summarised here, but there are numerous others that have been highlighted by the programme, these are covered in depth within section 4.

Effective communication, contractual arrangements and organisation are very important. These issues apply to the construction industry in general, but have a heightened importance when involving the introduction of a new technology such as PV: many DFT projects experienced delays and additional costs arising from poor communication.

Understanding of PV systems operation (e.g. DC wiring, Balance-of-System (BOS) equipment, siting), is also crucial to effective installation and operation. Providing information and training to project personnel and to tenants is an important step in this process. One site had initial problems because the inverters were placed over high stairwells

where access was almost impossible; a good example of lack of understanding of PV systems, their layouts and operational requirements.

Good co-ordination between PV system installers and other building tradesmen, particularly roofers and electricians, is also very important with PV systems where the two trades overlap. For example, one DFT site had numerous changes of personnel with poor handover procedures which has led to considerable additional work for the PV contractor.

In general, ensuring standards are applied/adhered to is very important. One PV tile product failed British Standards for fire testing when it was first introduced in the UK. This meant the product had to be modified, fitting metal 'fireguards' on the tiles, and fire tested in the UK before installation. Regional variations in building regulations can affect the design and/or pricing of the project, i.e. increased installation time. For example, Scottish regulations require that tiles are nailed to roof battens. Labelling is a key issue for Distribution Network Operators (DNOs) and attention to detail is required when finalising to ensure that the installation is acceptable to them.

Ensuring that good practice is maintained is also important, for example ensuring that cables are clipped neatly to rafters, without long lengths of spare cable, will generally help to improve customers' perception of the technology. Handover documentation should be well prepared and should cover all of the necessary points, especially safety, and must be in an easily readable format.

Data has been collected from all the PVDFT sites and this work is summarised in section 7. The presence of a central Monitoring Contractor has allowed a common data format to be established across all projects before data collection began. Requirements for measurement accuracy and frequency were also established at an early stage. Incoming data has been extensively checked, and many problems have been resolved at an early stage. This has also proved valuable in ensuring that solutions were quickly shared across the whole project.

Section 8 summarises the collection and analysis of performance data from the DFT projects, addressing the following key questions important for the development of PV systems on domestic properties in the UK.

- What is the typical performance of UK domestic PV systems installed in the UK in the period 2000-2005 and what are the influences of system design and location?
- Where significant losses are observed, over and above those that would be expected in normal operation, what are the causes and how can systems be designed to eliminate or minimise these?
- How much can the PV system contribute to meeting the electrical demands of the house on which it is installed?

The aggregated results from the DFT projects comprise the largest UK dataset allowing a robust assessment to be made. The analysis has considered both overall performance parameters and specific behaviour. Whilst it has focused on the reasons for reduced performance in some of the systems, many of the DFT systems are operating in line with expectation and providing annual yields above 800 kWh/kWp.

The analysis looked at system losses and made suggestions for reducing these. It emerged that inverter outages and shading problems are responsible for the highest losses, while dropout of the inverter due to high grid voltages is also a significant cause of loss.

The DFT has also investigated the contribution of the PV system to the building load. Results

show that even for fairly small system sizes of around 1.6kWp, a significant fraction of the building demand can be met by the PV system, either directly or indirectly. The majority of systems provide between 20 and 80% of the building load, with an average of 51%.

It is expected that the DFT data will continue to be an important research resource as new system designs and procedures are developed. It is already being used in work beyond the DFT.

As part of the PVDFT two surveys have been carried out within section 6, the Post Occupancy and the Post Selling Survey. This has shown that although developers are generally in favour of PV, they identify cost as the major obstacle. It is encouraging that many of the developers involved in the DFT are nevertheless considering using PV modules in future: the DFT has helped to shape developers' views and it has contributed positively to the development of the UK PV market.

Overall there is a very high level of end user acceptance but at the same time a clear lack of understanding about how PV systems work and might impact on (daily) routine, electricity costs and environmental credentials. This highlights the need for better user involvement and documentation to help clients and householders to understand the installation and operation of the systems.

Project cost information was analysed over all of the projects within section 5. Based on a system lifetime of 25 years the cost of the PV generated electricity was found to be between 20.9p/kWh and 184.7p/kWh with an average of 47.5/kWh. If known underperforming systems are removed, the average and maximum costs are 39.1p/kWh and 77.8p/kWh respectively. Although well above current electricity prices (about 8p/kWh) or the average buy-out contract tariffs (at about 7p/kWh) these figures nevertheless show that the average is significantly better than the average generally quoted (50p/kWh).

The combined average costs within the DFT for retrofit sites were £8.03/Wp (£5.90/Wp) whereas the new build sites were £7.24/Wp, including management and monitoring expenses. Comparison to the latest costs within the Major Demonstration Programme (MDP) where retrofit systems average at £6.34/Wp and new build installations at £7.40/Wp, would indicate that retrofit projects have actually realised higher cost reductions than new-build projects. However, a direct price comparison between the DFT and MDP is not possible, due to the different approaches of gathering and analysing data.

There is an overall trend of decreasing cost within the DFT, which correlates to figures within the MDP. This trend of decreasing costs is a sign that overall the PV market has gained confidence and is moving towards a more streamlined process. The lower costs for new build frame-mounted systems indicates that cost savings can be achieved when integrating PV, since the costs of site works, storage and scaffolding are shared by other construction works. Good planning and communication can help to further reduce costs.

The work identified issues critical to effective and efficient implementation of PV systems, both for installation and performance. To ensure that these issues continue to be disseminated a whole range of publications were produced together with workshops and participation at relevant third-party conferences. The publications produced within the DFT, dissemination efforts and management issues are summarised in section 9 and 10.

# Table of contents

Executive summary	4
Table of contents	7
Table of Figures	8
List of Tables	10
1 Introduction	11
2 Overview of projects	13
2.1 Ashley Vale, Bristol	13
2.2 BedZed, Sutton, South London	13
2.3 Berwickshire Ayton & Coldstream, Berwickshire	14
2.4 Bradan Road, Troon, Ayrshire	14
2.5 Broughton Leys, Milton Keynes	14
2.6 Campkin Court, Cambridge	15
2.7 Field Trials Belfast, Northern Ireland	15
2.8 Green Lane - Corncroft, Nottinghamshire	16
2.9 Greenfields, Maidenhead	16
2.10 Hockerton Housing, Nottinghamshire	16
2.11 Hunters Moon, Dartington, Devon	17
2.12 Llanelli (Gwalia), Wales	17
2.13 Machynlleth, Mid Wales	18
2.14 Montague Road, Edmonton, London	18
2.15 New Lane, Havant, Hampshire	18
2.16 Newbiggin Hall Estate, Newcastle	19
2.17 Newcastle Great Park, Northumberland	19
2.18 Panmure Street, Glasgow	20
2.19 Parson's Green, Guildford, Surrey	20
2.20 Perth Solar Active, Perthshire	20
2.21 Peterborough Homes, East Anglia	21
2.22 Pinehurst Estate, Liverpool	21
2.23 Pleasant Court, Nottinghamshire	21
2.24 The Power of Light, Northumberland	22
2.25 Sackville Street, Kirklees	22
2.26 St. Mellons, Cardiff, Wales	22
2.27 Steelstown, Northern Ireland	23
2.28 Stroud Cohousing, Gloucestershire	23
3 Installation methods	24
3.1 Integrated systems	24
3.2 Roof-mounted systems	35
3.3 Special/bespoke systems	44
4 Lessons learnt	47
4.1 Communication	47
4.2 Positioning and location	47
4.3 Good practice	48
4.4 Summary	49
5 System costs	50
5.1 System and installation costs	50
5.2 Electricity costs per kWh	54
5.3 Cost comparison	54
5.4 Summary	54
6 Survey results	56
6.1 Post selling survey	56
6.2 Profile of developers and householders	56
6.3 Decision to install PV systems	57

6.4	Installation issues.....	57
6.5	Impact of PV systems on sale price .....	58
6.6	Visual impact .....	59
6.7	Overview and recommendations for the future.....	59
6.8	Summary of Post Selling Survey.....	61
6.9	Post occupancy .....	61
7	Monitoring .....	71
7.1	The purpose of monitoring .....	71
7.2	Outputs required from the monitoring process .....	71
7.3	Quantities measured.....	71
7.4	Measurement accuracy.....	72
7.5	Data checking.....	73
7.6	Monitoring problems .....	74
7.7	Summary .....	80
8	Data analysis .....	82
8.1	Introduction .....	82
8.2	Data Availability and Analysis .....	82
8.3	Typical Performance Levels for UK Domestic PV Systems .....	83
8.4	System Losses .....	88
8.5	Contribution to Building Loads .....	95
8.6	Summary .....	96
9	Dissemination .....	98
9.1	List of outputs (as of January 2006) .....	98
9.2	General Publications.....	102
10	Management issues .....	104
11	Conclusions and recommendations .....	105
	Appendix 1 .....	111
	Appendix 2 .....	114

## Table of Figures

Figure 1: Fixing method of the Sunslates .....	25
Figure 2: Hook to hold down lower edge .....	25
Figure 3: The third row is installed and the tiles connected up by the roofer (photo – Laing Homes).....	26
Figure 4: Secure connection method.....	26
Figure 5: View of the Pfleiderer Terra-Piatta solar roof tiles on a number of adjoining properties.....	27
Figure 6: The complete Pfleiderer module (Solar Century) .....	28
Figure 7: Installation of the Pfleiderer Terra-Piatta solar roof tiles (BRE) .....	28
Figure 8: The Redland roof-integrated system .....	29
Figure 9: Counter battens (verticals) installed correctly for cooling, beneath battens.....	30
Figure 10: Plastic trays for weatherproofing with modules fitted on top.....	30
Figure 11: Showing the finished installation .....	30
Figure 12: Two of the properties using UniSolar Shingles .....	31
Figure 13: Shingle installation on felted board.....	31
Figure 14: Sealing with mastic.....	31
Figure 15: Detail of InterSole Trays from manufacturer data .....	32
Figure 16: An exploded view of the InterSole system. Note the fixing bolt detail (Manufacturer data) .....	33
Figure 17: Frame fixing method and side flashing .....	34
Figure 18: Lead flashing to lower tiles.....	34

Figure 19: Construction of PV Systems' RIS frame .....	35
Figure 20: Using scaffold tower to install the "Sun-in-a-box" system: laminates portrait, base structural rails horizontal .....	36
Figure 21: "Sun-in-a-box" system: laminates landscape, base structural rails vertical .....	36
Figure 22: Looking along the PV array as it is being installed, showing the steel channel and the "diamond" fixings .....	37
Figure 23: Section of Scottish practice roof, mounting hook and Unistrut module frame (BHA) .....	37
Figure 24: Klobber Tile with Special Attachment (picture Klobber) .....	38
Figure 25: Bracket design for flat concrete tiles .....	38
Figure 26: Construction of the frame .....	39
Figure 27: Illustrating the mounting method for modules in the AluTec system .....	39
Figure 28: The PV array mounted on the pitch roof using the Intersol mounting system .....	40
Figure 29: The Naps NSR retrofit system .....	41
Figure 30: View of the installed modules on the roof top .....	41
Figure 31: Ballast levelled off, dc cabling installed and irradiance sensors for monitoring equipment installed (Hockerton Housing Partnership).....	42
Figure 32: The installed frame-mounted PV system.....	43
Figure 33: Façade Integrate System in place using some "dummy" PV panels where there is increased shading.....	44
Figure 34: The modules mounted on the roof and wall of the conservatories.....	45
Figure 35: Once plugged together, the plug and socket connectors will be concealed and accessible.....	46
Figure 36: Double glazed unit.....	46
Figure 37: Accumulative cost break-down for components and installation per site .....	51
Figure 38 – Cost break-down for components and installation for different types of site .....	53
Figure 39: Average component and installation costs for all sites.....	53
Figure 40: Description of Developers involved in PV installations. (n=27) .....	57
Figure 41: House types and occupants description (n=27).....	57
Figure 42: Who led the decisions to use PV systems on the development. (n=25) .....	58
Figure 43: Appearance of PV system on house (n=27).....	59
Figure 44: Replies when asked about considering using PV in the future and motivation (n=40).....	60
Figure 45: Level of understanding by householders (n=239).....	63
Figure 46: Willingness to pay more for a PV house (n=49).....	65
Figure 47: Electricity savings and buy-back contracts (n=239). .....	66
Figure 48: Reasons for installing PV (n=146/171/78/61/10).....	68
Figure 49: Example of poor correlation between array output and radiation .....	75
Figure 50: An overshadowed solarimeter .....	76
Figure 51: Errors associated with 45° misalignment of solarimeter .....	76
Figure 52: Sample electricity meter calibration check (Colours denote different combinations of voltage and current to yield a given power).....	78
Figure 53: Errors introduced by using SMA inverter for DC power measurements .....	78
Figure 54: Sample corrections to SMA readings .....	79
Figure 55: AMPY meter conditioning boards.....	80
Figure 56: Measured annual yield values for PV systems at 17 sites and representing a total of 441 values. The average system size is 1.58 kWp and the average daily in-plane irradiation is 2.7 kWh/m <sup>2</sup> . .....	84
Figure 57: Annual yield values as a function of site location. The data are represented as a percentage of the total for each site to allow comparison, since the number of systems differs for each location category. ....	85
Figure 58: Variation of annual yield by PV technology. 81% of the systems use crystalline	

silicon modules. ....	85
Figure 59: Variation of PR values across 13 DFT sites .....	87
Figure 60: Illustration of inverter dropout for two PV systems on the same DFT site on a summer day. ....	89
Figure 61: The variation of AC output and in-plane irradiance with time for two similar systems on the same DFT site. The graph is for a winter's day with low irradiance conditions. System C is 20% larger in capacity than System D.....	91
Figure 62: Example of the effect of inverter threshold on the AC output at the beginning and end of the day. ....	92
Figure 63: Roof-integrated array with crystalline silicon roof tiles, where the left-hand side of the array is shaded by the adjoining building. At the extreme left of the picture some shading of the upper roof array can be seen.....	93
Figure 64: Example of the change in shading effect with season. In the summer, there is only a very small effect at the end of the day, whereas in the winter months, the output drops to very low values for almost half the day. ....	94
Figure 65: Annual solar fraction values for 15 DFT sites. The average system size is 1.6 kWp. ....	95
Figure 66: Variation of solar fraction with location. The average system sizes are 1.4, 1.5 and 1.7 kWp respectively for the three location categories. The occurrences are now expressed as a percentage to allow comparison. ....	96

## List of Tables

Table 1 – Comparative cost analysis showing the average deviation of costs for all sites, as well as average total costs (£/Wp) by installation type. The minimum figures do not take account of ‘zero’ values in order to avoid biasing the averages. The ‘Average deviation/average’ figures give a comparison of the variation from the average for all types of cost.....	52
Table 2: Cost comparison over the course of the PV Domestic Field Trial. Showing average costs in £/Wp and the percentage increase or decrease compared to the previous year...54	54
Table 3: Split of respondents into owner occupiers and tenants. ....62	62
Table 4: Overview of the different stages at which householders found out about the PV installation, broken down into length of occupancy and type of development (n=239). .62	62
Table 5: Extracts of replies from householders unhappy about the quantity and/or quality of system information made available (n=77). ....63	63
Table 6: Frequency of checking display.....64	64
Table 7: Energy efficiency measures in place. ....65	65
Table 8: Maintenance issues. ....68	68
Table 9: PV DFT system - Unpopular aspects.....69	69
Table 10: PV DFT systems – Customer opinion.....69	69
Table 11: Accuracies required from monitoring system .....73	73
Table 12: Schedule for submission of data over the two year monitoring period .....73	73

## Appendices

- Appendix 1 – Questionnaire for developers, Housing Associations and self-build
- Appendix 2 – DFT questionnaire for tenants/owner occupiers

# 1 Introduction

The UK Photovoltaic Domestic Field Trial (PV DFT) is the first wide spread monitoring of PV systems in domestic buildings in the UK. Its aim has been to use the design, construction and monitoring of the PV installations as a learning opportunity for utilities, building developers, Housing Associations and other key players involved in the process of PV installation and use. It has also aimed to identify barriers to the uptake of PV and hence define supporting work to remove these barriers.

Throughout the programme groups of domestic buildings were monitored through all phases of design, building integration, commissioning, and operation. This has allowed information to be collected under real UK climate and operating conditions.

Information has been gathered on ease of building integration, system reliability, maintainability and operating performance of domestic building based PV systems. This extensive amount of data from across the country has provided important and detailed information on system design, installation, performance and reliability. The information obtained from the DFT has been used to refine the guidelines for monitoring work, to improve the design of PV systems, to develop best practice guidelines, recommendations and case studies; and to inform the building and electricity industries about the suitability of the technology. It has also provided accessible examples of a wide range of domestic PV installations for both the general public and the planning authorities. The data is also being added to an international database being compiled by the IEA

The DFT involved a total of 28 projects, installing PV systems on a wide variety of domestic buildings. Each project was led by a different organisation often including other partners. To review the whole programme an independent Management Contractor was appointed, responsible for collating data from all of the projects in relation to construction, installation, performance and maintenance issues. The Building Research Establishment (BRE) as the management contractor worked in partnership with Northumbria Photovoltaic Applications Centre (NPAC) and Energy Monitoring Company (EMC), forming the PVDFT Consortium. Partners have included IT Power (phase 1 only), EA Technology and the Fraunhofer Institute Freiburg.

The PV Domestic Field Trial started with eight projects in 2000 (phase 1) and increased to 28 by late 2001 (phase 2). Within the 28 projects a total of 474 PV systems were installed in 217 buildings within private and public developments. The total installed capacity is 742kWp on 16 new-build sites and 10 retrofit, including two projects with both types.

This report has been prepared by the PVDFT Consortium. It conveys the experiences involved in the design, construction and operation of the systems installed at all sites. Monitoring activities have been carried out at all sites and data has been analysed from 17 DFT sites and a total of 274 individual PV systems. Data analysis continues and results for the remaining sites are expected to be available mid 2007.

This main intention of this report is to:

- Examine the different systems: type, size and appearance when installed
- Examine the different fixing methods, installation processes and their architectural integration
- Consider the costs of the different systems and hence likely cost trends

- Review common or frequent problems that emerged across projects, evaluating whether they are issues worthy of highlighting and disseminating in order to help future installations
- Present results for the Post Selling Review and Post Occupancy Survey which capture developer and householder views of the systems
- Review monitoring issues and lessons learnt
- Assess PV system performance results and recommendations
- Summarise dissemination activities
- Review operational issues related to the management of the PV DFT consortium's role within the programme

As this is the main project report, both technical and management issues are included. The first is aimed at informing the PV and building industries who are considering the feasibility of PV integration, i.e. architects, planners, PV designers, Housing Associations, etc. The report also assesses the key issues and barriers to the uptake of PV and defines supporting work to remove these barriers. It also offers an insight into potential installation and operational pitfalls so that these may be avoided in future projects.

## 2 Overview of projects

The following section summarises the technical details for each project. It is not intended to give any site specific information in regards to performance or views expressed by the developer or householders, as all of this information is expressed anonymously in the sections following this chapter. It is worth noting that the electricity suppliers vary between projects, and sometimes within a project where householders have chosen differing suppliers. This is discussed further in section 6.9 which looks at occupancy survey results giving feedback on electricity savings and green tariffs, as well as section 8.5 which looks at system contribution to building loads.

### 2.1 *Ashley Vale, Bristol*

- Private owner/occupiers
- New (self) build
- Roof-mounted Astropower AP120 modules
- 22 systems, 23.76kWp installed capacity
- Solar Century 'kit' – self installed following training
- Commissioned November 2004



Residents of the Ashley Vale area of Bristol formed an Action Group to find funding for the purchase of a former scaffolding yard in the area. Once the land was purchased it was divided into plots for self-build projects. One of their aims is to promote ecological and affordable housing within individually designed properties. Each householder was responsible for installing their own PV system, receiving support from other individuals within the Ashley Vale Action Group (AVAG). Initial training was provided by the PV supplier Solar Century. In regards to selling the electricity, most of the householders have opted for the Good Energy scheme which offered 4p per kWh of electricity generated (at the time of writing).

### 2.2 *BedZed, Sutton, South London*

- Private developer - Peabody Trust
- New-build
- Part social /part private housing
- Bespoke BP Solar modules
- Glass/glass customised BP Solar laminates
- 107kWp installed capacity
- Installer EETS and Active Cladding
- Commissioned February 2003



This ground-breaking zero carbon emissions development uses PV along with low energy technologies and a biomass combined heat and power(CHP) plant providing both heat and electricity to tenants. Standards of insulation are so high that the need for space heating is eliminated, though the hot water system has been designed to provide background heating to maintain minimum temperatures. Along with conventional modules on the roof, the installation features PV laminates installed within double-glazing units, which form the sloping roof and outside wall of the conservatories, thereby also reducing solar gain in the conservatories.

### ***2.3 Berwickshire Ayton & Coldstream, Berwickshire***

- Berwickshire Housing Association
- Retrofit and new-build
- Social housing
- Roof-mounted BP 585 laminates
- 18 systems – 36.72kWp installed capacity
- Installer – IT Power
- Commissioned July 2003



Within this project 18 grid-connected PV systems were installed in 17 BHA properties across four different sites. All systems use BP Solar BP585 laminates in a 2.04kWp configuration, apart from one site, where two systems were installed (4.08kWp). These properties also include significant additional energy efficient features and are providing valuable "before and after" information. Energy saving features installed within the new-build house includes solar thermal hot water, passive solar heating and heat pumps.

### ***2.4 Bradan Road, Troon, Ayrshire***

- South Ayrshire Council
- Retrofit
- Sheltered (social) housing complex
- Roof-mounted BP Solar 80Wp modules
- 31 systems – 29.76kWp installed capacity
- Installer – SunDog Energy Ltd. & local subcontractors
- Commissioned August 2003



The exposed location at Troon offers ideal conditions for monitoring roof-mounted PV systems. Within the sheltered housing complex 31 flats were retrofitted with PV panels. The roofs are orientated between 17° and 27° east of south since the road is on a slight curve. Each flat has an identical PV system, comprising 12 BP380 framed solar modules. The panels survived severe storms with gale force winds in January 2005.

### ***2.5 Broughton Leys, Milton Keynes***

- Bloor Homes and English Partnerships
- New-build
- Part social/part private housing
- Pfleiderer Terra Piatta solar tiles
- 17 systems – 36.7kWp installed capacity
- Supplier – Solar Century
- Installer – Solar Century/Bloor Homes & local electrical contractor
- Commissioned February 2005



This large new-build development at Broughton Leys, near Milton Keynes is based on the urban village principle and utilised roof-integrated

PV on 17 properties. Of these eight are terrace houses in a crescent shape, whereas the remaining houses were selected for their south-facing roofs. The house designs incorporate high energy performance (National Home Energy Rating – NHER score 10) with good standards of insulation, condensing boilers and low heat loss glazing. The Pfleiderer Terra Piatta solar tiles use Solarwatt crystalline modules. They take the place of six ordinary flat clay tiles.

## ***2.6 Campkin Court, Cambridge***

- Cambridge Housing Society
- Retrofit
- Private development – Brewer & Jackson
- Roof-mounted Kyocera polycrystalline 120Wp modules on flat roof
- One system – 22.1kWp installed capacity
- Installer – Dulas Ltd.
- Commissioned October 2004



This three storey 1960's apartment block was built to provide 23 homes for young professional women. Here the PV modules were frame-mounted on the flat roof within the plan of the building and it is therefore not visible from street level. The modules are mounted using the SolarMarkt AluStand system, specifically designed to support tilted modules on flat roofs. Detailed structural engineering calculations were done to ensure the system can withstand the worst possible wind uplift that could be expected at the site. The building has a number of energy saving features and the intention is to reduce fuel poverty. For health and safety reasons a guard rail had to be fitted around the edge of the roof, which means that a number of the modules are shaded, reducing overall output by approximately 5%.

## ***2.7 Field Trials Belfast, Northern Ireland***

- Northern Ireland Housing Executive
- Retrofit social housing
- Roof-mounted BP585 laminates
- 30 systems – 51kWp installed capacity
- Installer – BP Solar
- Commissioned March 2003



This project involved the refurbishment of three blocks of flats and consists of 30 PV systems, each comprising 20 BP Solar 585 modules. The PV laminates are mounted on a steel channel matrix using BP Solar “diamond” fastenings, held in place by roof hooks. High insulation and double glazing are among the rational use of energy features integrated at the site. One of the main lessons learned from this project is that it is wrong to assume the existing roof structure will be suitable for PV. In this case the flat roof was initially thought to be strong enough but a structural survey revealed otherwise. The Housing Executive was forced to rethink the project. The roofs were at the end of their design life and it was concluded that re-roofing of all three blocks would be the best option, offering the opportunity to mount the PV panels onto the sloping roofs.

## 2.8 Green Lane - Corncroft, Nottinghamshire

- Nottingham Community Housing Association
- New-build social housing
- Roof-integrated BP Solar 85Wp modules
- 22 systems – 34kWp installed capacity
- Installer – PV Systems & local sub contractor
- Commissioned April 2002

Green Lane - Corn Croft is a new-build social housing development. The 22 bungalows use a bright aluminium framing system sunk into the roof, ensuring the PV system is flush with the roof tiles. Parts of the development are located next to a busy road from which the south-facing PV modules are very visible. Ventilation is achieved by allowing an air gap between the modules and the roof when mounting the PV system. This results in lower operating temperatures and higher module efficiency.



## 2.9 Greenfields, Maidenhead

- Maidenhead & District Housing Association
- New-build social housing
- Roof-mounted Astropower 75Wp modules
- 15 systems – 20.25kWp installed capacity
- Supplier – Solar Century
- Installer – Solar Century & local roofing contractor
- Commissioned April 2001

This development near the centre of Maidenhead features environmentally friendly design is the largest Intelligent Green (Integer) housing project in the UK. Low energy features include passive stack ventilation for kitchens and bathrooms, light pipes, solar thermal collectors for hot water and PV. An inclined part of the roof was especially designed for the PV. The flat section allows easy access to the PV panels and is planted with Sedum grass, which reduces drainage and improves microclimate. .



## 2.10 Hockerton Housing, Nottinghamshire

- Hockerton Housing Partnership (HPP)
- Retrofit private housing
- Roof-mounted BP Solar 85Wp modules
- Six systems – 7.65kWp installed capacity
- Installer – Wind & Sun
- Commissioned October 2003

The HHP aims to live as a sustainable community incorporating environmental, economic and social aspects. The development consists of five ultra-low energy houses incorporating a large number of energy efficient measures. The five single story earth sheltered private properties were fitted with PV as part



of this project. The overall PV installation comprises 90 BP Solar 85Wp modules. These are fitted into waterproof consoles ideal for flat roofs. HHP receives many visitors and is very well publicised. The site includes a number of sustainability measures: double glazing, heat recovery mechanical ventilation, very high levels of insulation, grey water recycling and energy efficient appliances, all resulting in high SAP ratings. It also uses an air source heat pump utilising surplus heat from the sunspaces to heat domestic water and electricity from on-site wind turbines.

### ***2.11 Hunters Moon, Dartington, Devon***

- Private properties
- Retrofit private housing
- Roof-mounted BP 585 modules
- Eight systems – 8kWp installed capacity
- Supplier – Wind & Sun
- Installer – Cholwell Energy Systems Ltd; EETS Ltd (monitoring) and local roofing and electrical contractors
- Commissioned November 2001



This project involved the installation of a 1kW PV system onto each of the eight selected houses. It involves both flat and profiled concrete tile roofs with different mounting systems. Therefore new brackets and mounting systems had to be matched with existing roofing elements, which were about 15 years old at the time. Initial problems were overcome during the first installation allowing subsequent systems to be fitted within about a day each. The residents receive payment for exported electricity from SWEB based on annual meter readings.

### ***2.12 Llanelli (Gwalia), Wales***

- Carmarthenshire County Council/Tai Trothwy
- New-build social housing
- Roof and facade mounted BP 585U modules
- 21 systems – 28.6kWp installed capacity
- Installer – PV Systems
- Commissioned November 2002



Carmarthenshire County Council has developed this building in partnership with Gwalia Housing Association (now Tai Trothwy) in Llanelli. The building has 14 flats and features a range of integrated community services in partnership with a diverse range of public, private and voluntary organisations in the area. This includes a residential development for young people with common room and training facility and commercial space, residential flats, staff flats and reception and common rooms. The system consists of 336 BP 585U solar modules, with 16 modules integrated into the façade and the remaining 320 modules mounted on the roof as four individual arrays. The inverters were installed in the lofts or the flats' maintenance cupboards.

### ***2.13 Machynlleth, Mid Wales***

- CANTREF Housing Association
- New-build social housing
- Roof-mounted Solar Fabric 115Wp modules (using Astropower cells)
- Eight systems – 18.17kWp installed capacity
- Installer – Dulas & local roofing and electrical subcontractors.
- Commissioned November 2003



This housing association project's main aim is to showcase energy efficient housing and is appropriately located near the Centre for Alternative Technology. The modules are mounted onto an Intersole waterproof base designed to be mounted on ordinary felt and battens and to provide the modules with back ventilation. They interlock with a range of adjacent roofing types. In this case they are edged with Welsh slate in keeping with the local character. The Astropower cells were produced by Solar Fabrik of Freiburg, Germany, totalling 19kWp installed and supplying eight flats and two bungalows.

### ***2.14 Montague Road, Edmonton, London***

- Laing Homes
- New-build private housing
- Roof-integrated Atlantis Sunslates
- Nine systems – 14.54kWp installed capacity
- Installer – Solar Century & local roofing contractor
- Commissioned April 2001



This development is a showcase for a wide range of sustainable features. Not only do the houses boast good energy efficiency, but water and waste recycling facilities are prominent in the designs. Furthermore construction waste was minimised and wood sourced from managed forests. This speculative development gave an opportunity to examine the saleability of properties with PV. The developer was keen on a non-intrusive appearance and opted for PV tiles rather than modules. A fibre cement tile was selected to match the appearance of the conventional tiles. Consequently visual integration is very high. The total installed capacity is 14.54kWp supplying nine properties. The tiles were installed by the roofing contractor with little extra instruction. The results of the post selling survey are given in section 6.1.

### ***2.15 New Lane, Havant, Hampshire***

- Hermitage Housing Association
- New-build social housing
- Roof-mounted BP 585 laminates
- Nine systems, 13.8kWp installed capacity
- Installer – PV Facades
- Commissioned March 2004



This project comprises nine new-build properties

providing social housing. The modules were connected on the roof such that each property is supplied by a 1.53kWp PV array. A whole range of sustainability features were adopted within this brownfield site development comprising rainwater collection, solar water heating, warmcell insulation and timber frame from sustainable sources in order to achieve excellent ratings within Eco-Homes and SAP (sustainable building and energy rating tools). The site also offers a large plot to householders wanting to grow-your-own vegetables.

### ***2.16 Newbiggin Hall Estate, Newcastle***

- Newcastle County Council
- Retrofit social housing
- Roof-mounted BP Solar 85Wp modules
- 25 systems, 38.25kWp installed capacity
- Installer – PV Systems
- Commissioned June 2004



Newcastle County Council was responsible for refurbishing this 25 unit block of mid-rise flats of social housing in Westerhope. Each of the 25 PV systems is installed as a roof-integrated system, with a total installed capacity of 38.25kWp. The overall system comprises 450 BP Solar 85Wp laminates mounted in four sub-arrays onto separate roofs above the flats. The support structure used is the RIS system developed by PV Systems. The consumer display units, instead of being positioned inside each flat, are located next to the meter cupboard on the ground floor. This decision was taken in order to minimise tenant disruption and to be able to install all the metering in one go.

### ***2.17 Newcastle Great Park, Northumberland***

- Bryant/Taylor Woodrow & Persimmon
- New-build private housing
- Roof-mounted BP Solar ‘Sun in a box’ system
- Roof-integrated Redland PV700 tiles
- 12 systems, 17kWp installed capacity
- Installer – SUND OG energy Ltd & Winsund
- Commissioned June 2004



Newcastle Great Park is an example of a new-build, private development and consists of PV systems on twelve individual houses, ten using Redland PV tiles (integrated) and two using BP Solar ‘Sun in a box’ systems (roof-mounted). The team wanted to demonstrate integrated and retrofit systems side by side to allow new customers to make an informed choice about which type of PV system they prefer. In addition, the team were keen to compare the two systems during the construction process. The project involved two housing developers with different processes and as a result, the sites were installed very differently.

## ***2.18 Panmure Street, Glasgow***

- Queens Cross Housing Association
- Retrofit social housing
- Roof-integrated Astropower 120Wp modules
- 12 systems, 12.96kWp installed capacity
- Installer – ESD/Solar Century & local roofing and electrical contractors
- Commissioned December 2003



Queen's Cross Housing Association is responsible for this four-storey block of flats, comprising 12 units for adults with low incomes. The block of flats is orientated to the south allowing PV modules to be installed on the south-facing roof area. The total installed capacity is 12.96kWp. The DNO, Scottish Power, fully supported the scheme wanting to gain hands on experience in developing renewable energy and their effects on metering. One of the main aims of using PV was to help alleviate fuel poverty in this area of Glasgow.

## ***2.19 Parson's Green, Guildford, Surrey***

- Guildford Borough Council
- New-build social housing
- Roof-integrated Pflleiderer 'Terra Solar' tiles
- 11 systems, 25.2kWp installed capacity
- Supplier – Solar Century
- Installer – IT Power/Solar Energy Installations
- Commissioned September 2003



PV is integrated into eleven new-build homes in Parsons Green, in the Slyfield area north of Guildford. The development comprises a range of houses and bungalows used for social housing. Pflleiderer "Terra Solar" PV solar roof tile systems are fitted to each house, delivering a total of 25.2kWp. This system was chosen by the developer because it is roof-integrated thus simplifying and speeding installation. The buildings were used to educate visitors on sustainability issues using a pre-occupancy exhibition.

## ***2.20 Perth Solar Active, Perthshire***

- Perthshire Housing Association
- Retrofit and new-build social housing
- Roof-integrated Atlantis sunslates and roof-mounted Pflleiderer modules
- 24 systems, 55.8kWp installed capacity
- Installer – Solar Century and local roofing & electrical contractors
- Commissioned March 2003



This project consists of PV installations at three housing developments in Perthshire, Scotland. The developments at Pitlochry and Bankfoot were "new-build" whereas that at Glenlyon was refurbishment. There are three PV systems at Glen Lyon and five at Bankfoot, all utilising Atlantis Sunslates. The 15 systems at the Pitlochry site use Pflleiderer modules,

giving a somewhat different appearance, in keeping with the more modern design of the houses. In total there is an installed capacity of 55.8kWp. This project allows the comparison of two PV integration methods as well as new-build versus refurbishment. The sites also included a number of energy efficiency measures to further reduce overall energy demand.

### ***2.21 Peterborough Homes, East Anglia***

- Nene Housing Society
- New-build social housing
- Roof-integrated United Solar ‘Solar Shingles’
- 14 systems, 25.8kWp installed capacity
- Installer – Solar Century and local roofing & electrical contractors
- Commissioned March 2003



This project formed part of the (then) largest new social housing development in Europe. PV shingles were integrated into nine houses and seven bungalows. The shingles are designed to easily interface with ordinary roofing shingles and can be nailed in place over plywood or similar decking. Visual integration is achieved by making sure the PV shingles are lined up to the position of the windows and front door. The solar tiles and shingles look very similar and it is therefore (usually) impossible to spot the difference between both when looking up from ground level.

### ***2.22 Pinehurst Estate, Liverpool***

- Plus Housing Group
- New-build social housing
- Roof-integrated Redland PV700 tiles
- Nine systems, 13.72kWp installed capacity
- Installer – SunDog and building contractor
- Commissioned November 2002



Within the estate’s renovation programme, nine of the 55 houses were deemed to be beyond economic repair. Hence the decision was taken to build nine new properties incorporating photovoltaics. The Redland PV700 tile system was chosen because the rest of the estate uses conventional Redland tiles. There are 40 PV tiles (1.4kWp orientated 55° W of S) on five smaller houses and 48 tiles (1.68kWp orientated 24° W of S) on four larger ones. One PV tile displaces four conventional tiles and they are designed to fit in with the conventional tiles’ horizontal lines resulting in flushness with the roof. The overall result is an uncluttered roof with an eye-catching PV system whereby the effect of contrasting red tiles and blue PV modules was deliberate.

### ***2.23 Pleasant Court, Nottinghamshire***

- Nottingham City Council
- Retrofit social housing
- Roof-mounted Astropower AP1206 modules
- Eight systems, 11.52kWp installed capacity
- Supplier – Solar Century (also training)
- Installer – Nottingham City Building Works
- Commissioned June 2004



Situated in the inner city area of Nottingham known as Hyson Green, Pleasant Court flats were built in 1963. As part of the refurbishment it was decided to integrate PV modules and the installation comprises a total area of 93m<sup>2</sup> of monocrystalline Astropower PV panels. The total peak output is 11.52kWp, with 1.44kWp for each housing unit. In addition to the installation of the PV systems, a number of energy efficient improvements were implemented, including double glazing and roof & cavity wall insulation, as well as changing the heating system from electric to gas. All these measures combined allow tenants to benefit from significant energy savings.

## ***2.24 The Power of Light, Northumberland***

- Wansbeck District Council
- Retrofit social housing
- Roof-mounted BP Solar 'Sun in a box' system using BP585 laminates
- Ten systems, 15.3kWp installed capacity
- Installer – Windsun
- Commissioned June 2005



During the course of the modernisation and refurbishment ten BP Solar "Sun in a box" PV roofing systems were fitted on the Churches Estate in Ashington. This was combined with other energy efficiency measures such as installation of double glazing with low E-glass, cavity wall insulation, and high levels of loft insulation. Each PV system provides 1.5kWp to individual flats, with a total array size of 15.3kWp. The modules are located on the roof space of five buildings at tilt angles of 20°.

## ***2.25 Sackville Street, Kirklees***

- Kirklees Metropolitan Council
- Retrofit social housing
- Roof-mounted Astropower modules
- 30 systems, 30.4kWp installed capacity
- Installer – ESD/Solar Century and local roofing & electrical contractors
- Commissioned April 2003



This project consists of 30 PV systems mounted onto existing residential units at a social housing development in Kirklees. The total installed capacity is 40kWp on a combination of houses and flats, comprising a total of 30 systems (22 houses & 8 flats) with system sizes ranging from 0.96kWp to 1.68kWp according to roof space/dwelling layout. The Astropower modules AP55, AP75 and AP120 were installed using the Alutec mounting system.

## ***2.26 St. Mellons, Cardiff, Wales***

- Cardiff County Council
- Retrofit social housing
- Roof-mounted NAPS Solar roof system
- 16 systems, 16.4kWp installed capacity
- Installer – Filsol & local electrical contractors



- Commissioned August 2003

This project involved the installation of 16 PV systems, each of 900 Wp, within the refurbishment of social housing in the regeneration in the St. Mellons region of Cardiff. Here 16 properties were selected for PV demonstration because of their suitable orientation and shading. NAPS SolarRoof systems are installed, using NAPS' SlideIn™ roof mounting system. The installer decided to pre-assemble the major PV system components to facilitate speedy and effective on-site installation.

### ***2.27 Steelstown, Northern Ireland***

- North and West Housing Association
- New-build social housing
- Roof-mounted BP 585 laminates
- 25 systems, 51kWp installed capacity
- Installer – PV Systems
- Commissioned March 2003



Within the Steelstown Estate 25 properties were selected for PV integration. The properties included bungalows, houses, semi-detached maisonettes and one flat. This was part of a programme developing 80 low-cost dwellings. The PV systems are integrated into the south-facing roof using the PV Systems "RIS" system. The properties are situated on a high profile development that is expanding to provide housing for local residents.

### ***2.28 Stroud Cohousing, Gloucestershire***

- The Stroud Co-Housing Company Ltd.
- New-build private housing
- Roof-integrated Redland SRT35 tiles
- 20 systems, 49.4kWp installed capacity
- Installer – SunDog, local roofing & electrical contractors
- Commissioned April 2004



Within Stroud Cohousing 20 PV systems were installed, in addition to many other environmental measures, in order to minimise the properties' "environmental footprint". The buildings are 2-storey 3, 4, and 5 bedroom houses. Three different array sizes were used, 2.03kWp within eight plots, 2.24kWp within six plots and 3.29kWp also within six plots. The living environment is designed to be as sustainable as possible, with features such as sustainable urban drainage system (SUDS), car sharing, communal dining room, passive solar heating, rainwater harvesting and timber frame construction using sustainable timber.

### **3 Installation methods**

The following section reviews the installation methods used within the PV DFT only and is not a complete overview of all installation methods and systems available on the market. More detailed guidance is available from other publications [<sup>1</sup>].

PV installations on roof tops are of two types, either integrated or roof-mounted. Integrated systems are those in which the PV system becomes part of the roof covering, i.e. forming the weather skin of the building. In this case PV modules (laminates, frameless modules) or tiles actually replace some of the conventional roof covering. Roof-mounted systems incorporate PV modules/laminates in a specific structure or mounting system and the final product is located above or, in the case of flat roofs, on the existing roof covering/structure.

Either type of installation is suitable for new or existing buildings. In new-build installations PV is (ideally) included during the design phase and is therefore more easily integrated into the construction process. In contrast retrofit refers to installations where the PV is fitted onto an existing roof. These may be integrated, but more usually they are simply mounted above or, in the case of flat roofs, on the existing structure. In retrofit situations a roof-integrated solution should only be considered if it coincides with other roofing work, i.e. replacing the roof structure, or part of it. It should be noted that to remove a perfectly good roof in order to integrate a PV system is not considered to be good practice.

Out of a total of 28 projects, 14 sites installed roof-integrated systems and 17 sites opted for roof-mounted systems. Some of the projects spread their installations over a number of sites and/or used a variation of installation methods. The 14 roof-integrated sites used various different types of PV tiles and PV modules/laminates, all of which were on new-build projects, except one where the original roof covering needed replacing. Similarly the 17 sites opting for roof-mounted systems also used a combination of installation systems and methods, including two flat-roof-mounted systems. There were also two sites that installed façade/bespoke systems integrated into the façade and/or roof.

#### ***3.1 Integrated systems***

##### **3.1.1 Tile-based systems**

Of the 14 roof-integrated installations, ten used tile-based integration, with the other four sites using laminate/module integrated solutions. There were four different tile-based system designs and two different laminate/module systems designs used.

Arguably tile-based systems blend into the roof more easily, although as with module/laminate systems this still depends on the surrounding roof covering. One reason for project teams choosing tile-based systems was because they felt the PV tiles would be complimentary to the scheme and surrounding area. In some cases this required “dummy” tiles to be installed, which look like PV tiles but in fact do not produce electricity. They are designed to limit the visual impact of PV tiles by matching and balancing the overall roof appearance. In cases where a specific PV system is allocated to a certain property, care needs to be taken with roof layout to ensure that PV panels are located on the appropriate part of the roof. For example in semi-detached situations it is important to avoid installing PV tiles across any part of a neighbour’s roof, not only for visual effect but maintenance and

---

<sup>1</sup> Planning and Installing Photovoltaic Systems – A guide for installers, architects and engineers; The German Solar Energy Society and Ecofys; James & James (2005)

ownership reasons. So rather than having one PV tile system across the whole building block, owners are able to identify “their” system and rest assured that it only produces power for their property.

**3.1.1.1 Atlantis Solar Sunslates**

Atlantis Solar Sunslates were used on three sites, one of which was retrofit, with concrete and with slate tiles. Ordinary roofing contractors completed all the installations having had training from PV engineers.

The Sunslates are of European standard sizes and hence the roof battening had to be spaced accordingly, different to normal UK practice. Counter battening had to be installed to provide some back ventilation for the Sunslates. The extra thickness of the south-facing roof due to the counter battening was compensated in part by the fact the solar tiles were thinner than the conventional ones on the other parts of the roof. However, some non-standard work was required to ensure the surfaces matched sufficiently well at the edges.

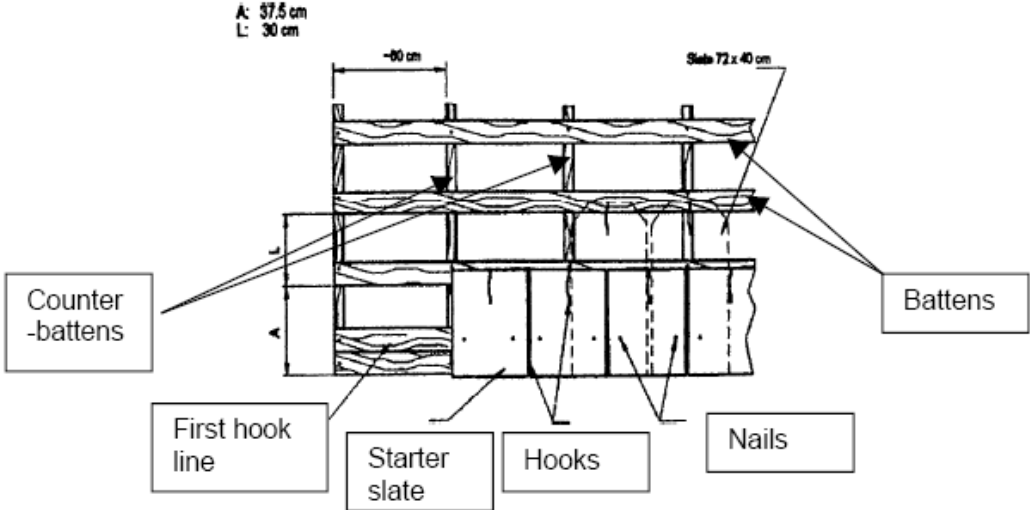
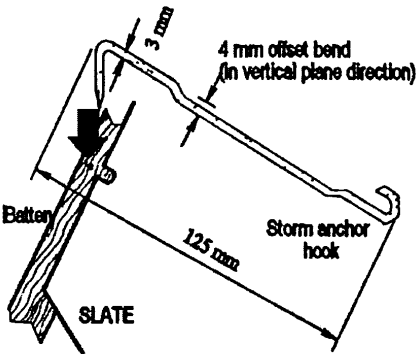


Figure 1: Fixing method of the Sunslates

As can be seen in Figure 1, the bottom and first row to be installed require extra attention. The diagram also shows the counter battening which raises the fixing battens off the surface to allow ventilation. Even though the extra cost of this work was negligible it did require additional design considerations. Figure 2 shows proprietary hooks which serve to hold down the lower edge of the next row of slates. Details of an anchor hook are also given, its’ pointed tip allows it to be hammered into the top batten.

Figure 2: Hook to hold down lower edge

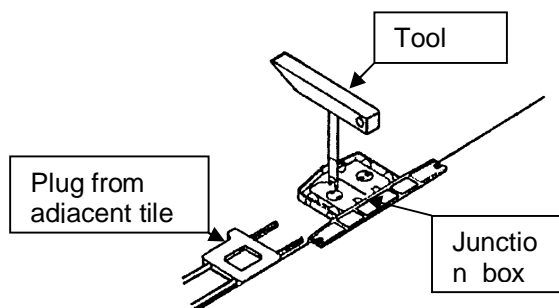




*Figure 3: The third row is installed and the tiles connected up by the roofer (photo – Laing Homes)*

The process of attaching the tiles also differs from common practice. Whereas normally they would be laid along the diagonal Sunslates have to be laid in rows (bottom of roof to top). This makes the process slightly more difficult as the roofer has to lean downwards over the tile in order to attach it, rather than sideways (Figure 3). The reason for this is that the tiles are required to be connected to each other side by side, and the continuity of the connections is checked after each row. This ensures the PV tiles within each row operate correctly before the next row is laid.

This added requirement needs to be completed by an electrician or other trained person, as the open circuit voltage in a typical string can be in the region of 150 – 200Vdc, so suitable safety precautions need to be taken. These Multi-Contact (MC) connections themselves are simple as can be seen in Figure 4. The plug to the left is inserted into the junction box and the special tool rotated to secure the plug well in place. Considering the expected functional lifetime of the Sunslates, these connections have to be of high quality. However when applying this method even unskilled (non-electrical) personnel can carry out this work resulting in long lasting connections, keeping in mind that the testing should be done by a skilled person. Although the installation time was about twice that of an ordinary roof, the roofers completed the work within a fixed price contract.



*Figure 4: Secure connection method*

### 3.1.1.2

### 3.1.1.3 Pfleiderer Terra-Piatta Solar Roof Tiles

Pfleiderer Terra-Piatta solar (PV) roof tiles are designed to integrate with Terra Piatta conventional tiles. They are specified to interlock with one another and match each other visually. This integrated system hides all mounting parts and presents clean horizontal lines to the observer very much in keeping with the look of the tiles themselves. The architectural intention is that the PV blends into the overall roof flushing without being very noticeable. Even though the Pfleiderer modules are quite large, displacing six ordinary tiles. (see Figure 5) they fit in well with the grid of the roof since they are only one tile deep, accentuating the horizontal lines.



*Figure 5: View of the Pfleiderer Terra-Piatta solar roof tiles on a number of adjoining properties*

These European PV tiles interlock easily with Terra Piatta clay tiles, although not with conventional British concrete tiles due to the different dimensional base between the UK and Europe. In more than one project where conventional tiles were used instead of the Terra Piatta clay tiles they had to be cut to fit correctly. In one case this avoided over-hanging the guttering, which would have left an orange edge exposed. Considering this was then visible from ground level it had to be painted black.

Figure 6 shows the Pfleiderer modules. Note the water channels along the sides, and profiled top edge to interface with other modules and conventional roof tiles from the Terra Piatta range. Each solar tile takes the place of six conventional tiles and the electrical connections were made via factory fitted plugs (also called MC plugs). In some projects roofers were trained to install and make and test the electrical connections.



Figure 6: The complete Pfleiderer module (Solar Century)

The sequence of installation (Figure 7) is from the base up, with each module top edge being screwed to the battens. Tiling is carried out below and to the right of the array. The first module is laid on battens and the dc cable is connected to the output cable using push fit MC (*Multicontact*) plugs. The module is then screwed through the tray to the battens in three places. The subsequent modules are connected using MC plugs and screwed down in a similar way. The module tray interlocks with adjacent modules and tiles for a weatherproof join and the final MC plug from the top of the array feeds into the output cable to the inverter.



Figure 7: Installation of the Pfleiderer Terra-Piatta solar roof tiles (BRE)

Re-battening was required on some of the first installations in order to accept the different sized clay tiles (Figure 7). The modest cost of this (about £200) was considered to be a reasonable part of the learning process for new constructions. Another extra task involved the fitting of a black stainless steel shroud to edge the modules. This was designed to enable the modules to pass the British spread-of-flame test (BS476). This resulted in increased installation time, as each module had to be glued manually. However this has instigated the development of a factory-based solution.

One project team experienced a problem with the supply of matching Terra Piatta clay tiles, and alternative tiles had to be sourced. The alternatives did not interlock completely and sealant had to be applied between the PV and roof tile. Although this worked adequately it cannot be considered an ideal solution. It also added cost in terms of the time required to

devise and implement a solution. In addition the changed roof tile dimensions led to an alignment problem with the PV tiles and alterations were required while the installation was on-going. The alterations had to take into account that each property had their own allocated PV system while maintaining high visual roof integration (i.e. each system had to be a single unit as they are visible from the ground and were therefore not allowed to infringe onto the neighbour's roof). Thus the importance of ensuring supply of non-standard items, other than the PV system, i.e. in this case, unusual roof tiles, cannot be over stated.

#### **3.1.1.4 Redland PV 700 Roof Tiles**

The Redland PV 700 solar power system features a frameless 35Wp PV module that directly replaces four conventional Mini Stonewold concrete roof tiles. Redland PV 700 roof tiles were used on three sites within the programme, all of which were new-build properties. *Figure 8* shows one of the Redland installations which illustrates the flushness of the modules with the roof. It also illustrates that the clips are almost hidden which results in uncluttered lines, giving a neat, well-designed appearance.



*Figure 8: The Redland roof-integrated system*

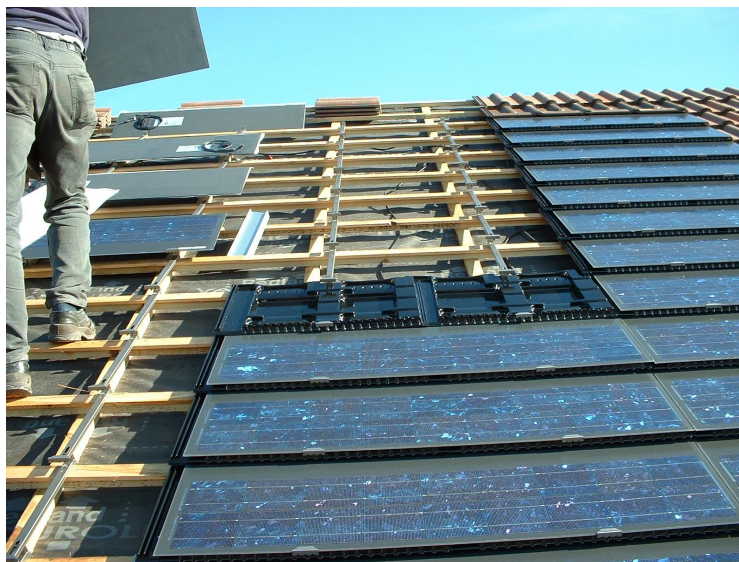
Feedback from project teams indicates that installing the Redland mounting system was generally found to be straightforward. On the first roof on one site roofers put the felt between the counter battens and the battens instead of underneath both, reducing the ventilation air gap. It is worth emphasising the correct sequence of counter battening here as this is unusual roofing practice. In this case the battens of one site had to be re-done but did not add significant delay (Figure 9).

Roofers were able to connect the modules as they progressed using the Multi-Contact (MC) connections mentioned in section 3.1.1.1. Prior to this the main DC cables had been installed, either by the main PV contractor or in some cases by the site electrician. After all the modules were installed string continuity was checked, either by the electrician or PV contractor to ensure that connections are working (on one site the PV contractor returned to complete this activity before the scaffolding came down.). This is crucial to ensure that any poor connections are located whilst access is still available.

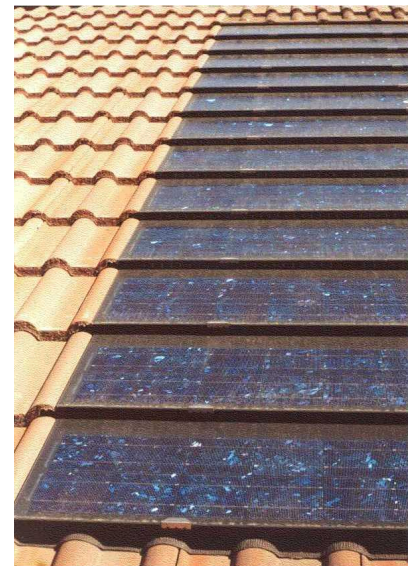


*Figure 9: Counter battens (verticals) installed correctly for cooling, beneath battens*

Figure 10 shows the installation process in two stages. First the proprietary plastic tray is fitted which meshes in with the Redland tiles, giving weather-tightness and back-ventilation. Secondly, the modules' MC connections are connected together and clipped into place. One potential concern voiced by installers was that in order to replace failed panels or to test connectors, access would only be possible by removing the panels from the top down. Figure 11 shows a finished installation.



*Figure 10: Plastic trays for weatherproofing with modules fitted on top*



*Figure 11: Showing the finished installation*

### 3.1.1.5 UniSolar Shingles

One development, comprising eight houses and six bungalows, used the roof-integrated UniSolar PV shingles (SHR 17 thin film solar) (Figure 12). The PV strips are about 3.66 m wide and 2.13 m long with 1.52 x 3.66 m exposed tabs and 5.49 m long wire leads to drop through into the attic. Each PV shingle produces 17 watts at a nominal 6-volts so the shingles are connected in series and/or parallel to match the inverter input requirements.



*Figure 12: Two of the properties using UniSolar Shingles*

Figure 13 and Figure 14 show the installation completed on a pair of semi-detached houses. These solar cells use amorphous silicon triple junction technology, encapsulated within a high transparency Tedlar with a pyramid like top surface for good light absorption. They are designed to interface easily with ordinary roofing shingles and can be nailed in place over plywood or similar decking.



*Figure 13: Shingle installation on felted board*



*Figure 14: Sealing with mastic*

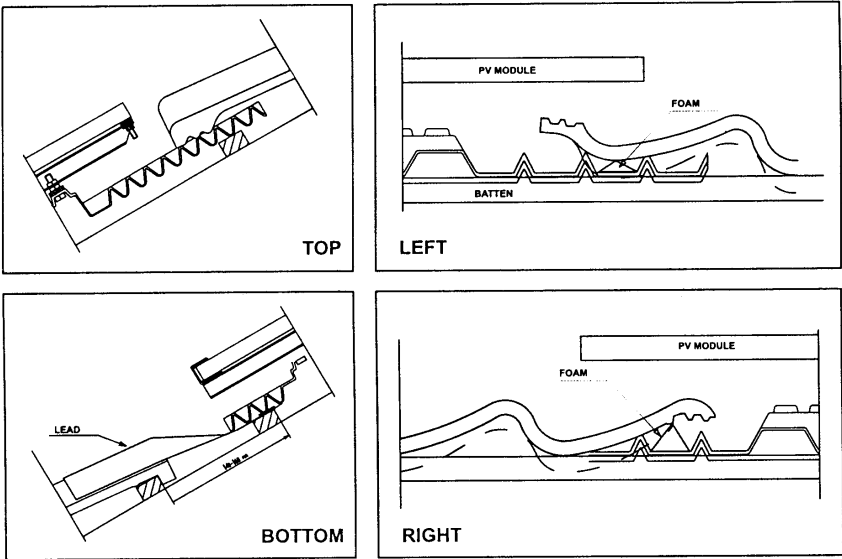
Overall the installation on a sloping felted plywood or similar roof deck is relatively straightforward. The first shingle is fastened with 5 nails and a hole is drilled under the third cell through the roof deck into the attic for the connecting wiring. The lower edge of the shingle is sealed to the roof felt with mastic and the next shingle is fitted above so the PV part covers the plain part of the shingle below. Again the lower edge is sealed down with mastic. Initial progress can be slow for installers new to this process but experience within the DFT has shown that installation soon sped up as the process became more familiar and as more staff were trained.

**3.1.2 Module/laminate systems**

There were two different module/laminate roof-integrated systems used within the PV DFT, the Econergy InterSole system and PV Systems’ RIS (Roof-integrated System): the former was used on only one site whilst the latter was used on three sites.

**3.1.2.1 Econergy InterSole system**

The InterSole tray system is designed for integrating all brands and types of solar panels in sloping roofs. It mounts onto the roof using overlapping plastic sheets and special anchors and is designed to make a weatherproof joint to a variety of types of tiles and slates. The sheets are made of recycled, low-maintenance 100% chlorine-free plastic which can be easily cut to match any sizing requirements of the roofing elements or modules. Also the rippled edges channel water away from the joins as well as providing an interlocking means with the adjacent tiles or slates (Figure 15: *Detail of InterSole Trays from manufacturer data*).



*Figure 15: Detail of InterSole Trays from manufacturer data*

In the one case where it was used the InterSole system proved more difficult to use than expected. The difficulty arose while attaching the modules to the InterSole trays rather than in the interface with the slates, as in previous roof-integrated examples. The first few installations took much longer than later ones as they had to be dismantled and assembled again in the correct order. During initial assembly it was noted that if the fixing stud was not completely tight when attaching the module, access to the required nut was impossible. The installers decided to attach extra locknuts to ensure the brackets and studs did not become loose. This added extra complexity to the fixing stud assembly.

The InterSole tray can be used with profiled tiles or, as in this case, with slates. However in

order to make the slates flush with the modules an extra batten had to be installed underneath the slates. This raises them to the same height as the PV modules on the InterSole trays where only a single batten was required. The trays require screwing to the studs through a ridge in their profile, which ensures no water entry. They took more time to install than the modules, even though they are easier to handle. Once the order of assembly was established the installation time was reduced by a half. Figure 16 shows a single stud for attaching the modules. In practice this consisted of two studs connected by a plate, a total of 5 nuts per fixing and 532 fixings altogether. The difficulty here was that no parts list (and only limited assembly instructions) were provided by the manufacturer. It is therefore essential for the supplier to provide this information.

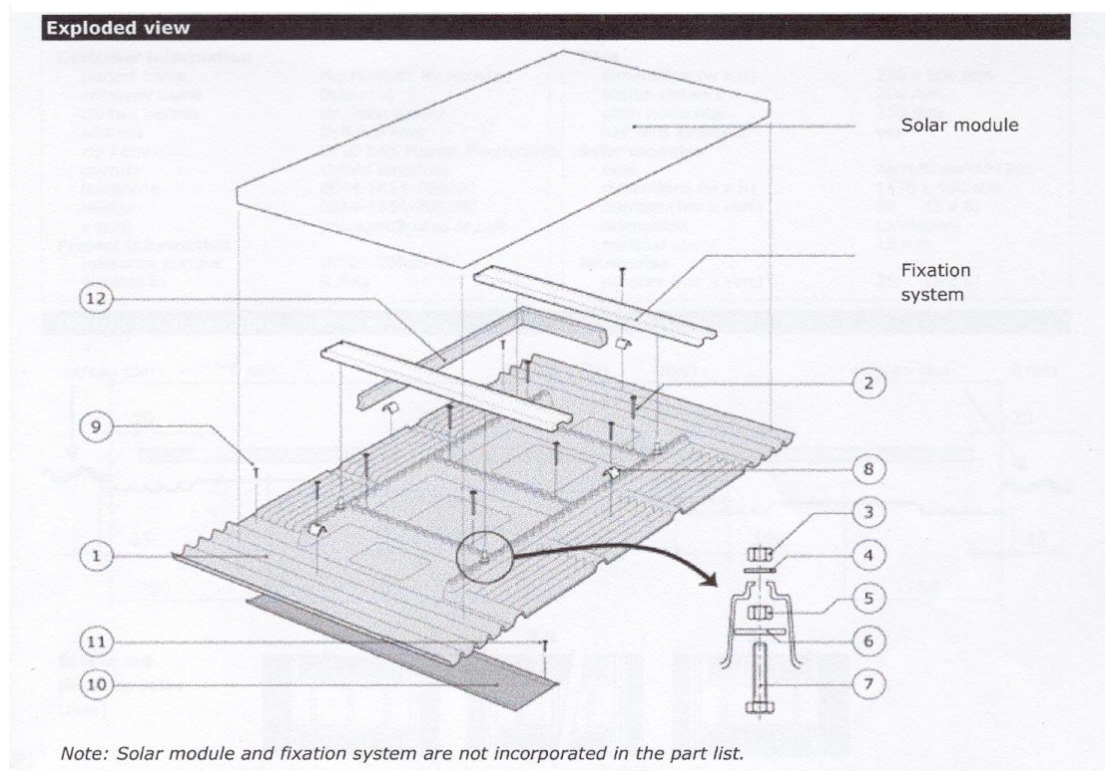


Figure 16: An exploded view of the InterSole system. Note the fixing bolt detail (Manufacturer data)

An L-shaped bracket is used to join the Interflex rails to the InterSole base units. The wood screws supplied are designed to suit Dutch batten dimensions and were found to be too long for British standards. They therefore could have penetrated battens and the sarking felt, potentially causing moisture ingress. This was recognised and shorter screws were used. Again this indicates that products designed for the European market may not fit directly into the UK context.

### 3.1.2.2 PV Systems' RIS (Roof-integrated System)

PV Systems' RIS (Roof-integrated System) utilises standard PV modules within an aluminium frame which is sunk into the roof, thereby enhancing visual integration as the modules are flush with the roof tiles.

The PV Systems' aluminium frame system interlocks with the tiles to the sides to provide a watertight joint. Side flashings of preformed aluminium sheet interface the end mainrail with the profiled roofing tiles. Flashing is installed around the bottom of the frame, similar to flashing systems used in Velux or Colt type roof windows. Each module is surrounded by an EPDM gasket for weather resistance and the modules are laid onto the frame. A cap strip is

then riveted down to further seal the joint between the modules.

Figure 17 illustrates the frame fixing method, Figure 18 the lead flashing integration with the conventional tiles and Figure 19 shows the construction of the PV System's frame.

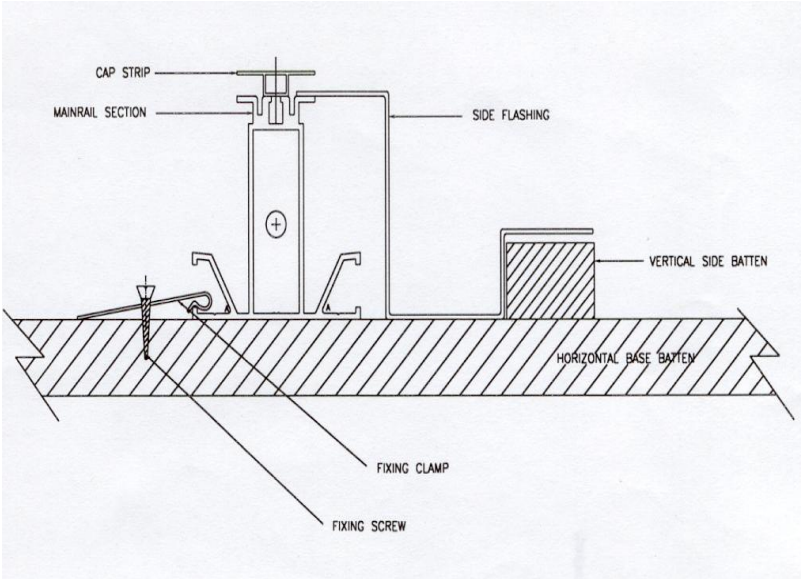


Figure 17: Frame fixing method and side flashing

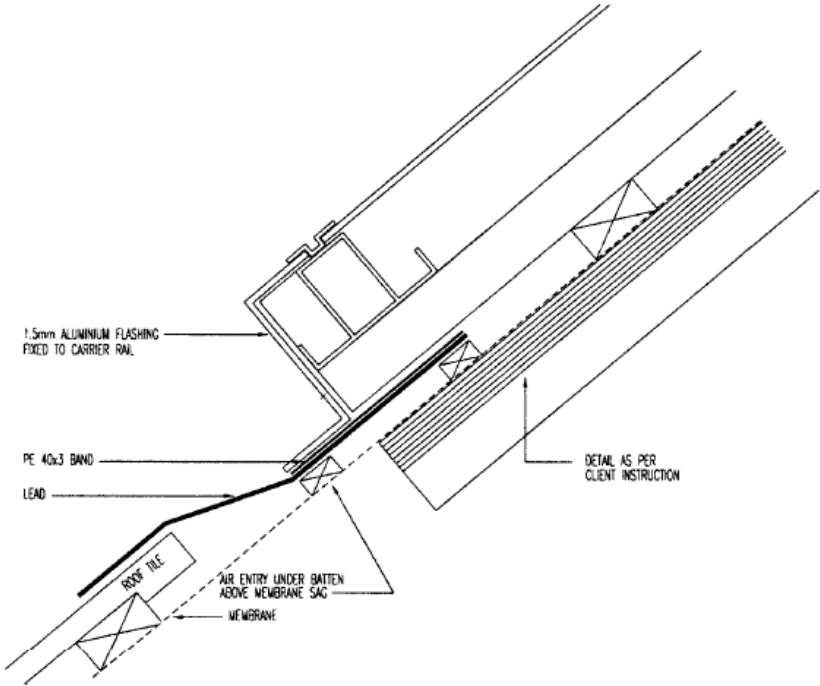


Figure 18: Lead flashing to lower tiles

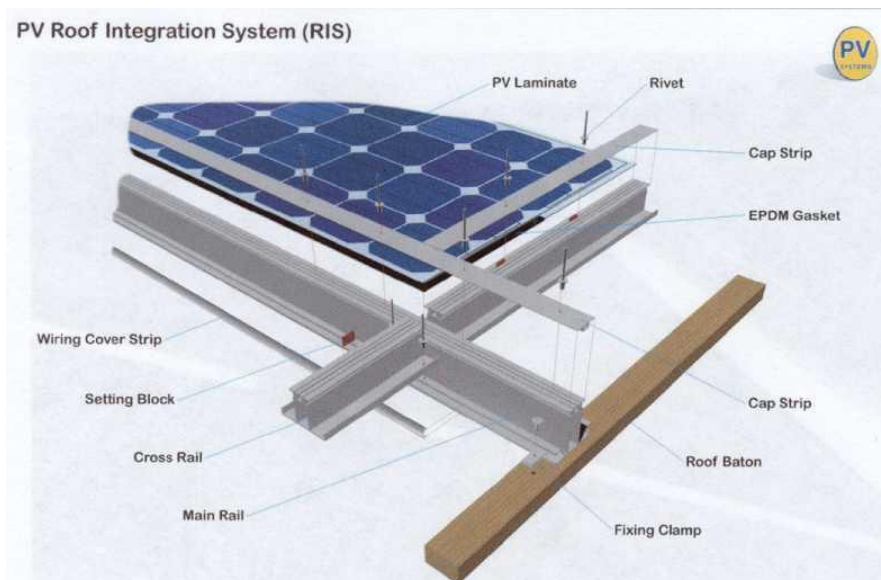


Figure 19: Construction of PV Systems' RIS frame

These PV systems are unusual in that they are roof-integrated using modules on a pre-assembled structural frame. This is usually completed at a factory as the frame assembly requires mechanical precision. These smaller units (x 6 modules) are joined together in situ as their size allows them to be easily manhandled onto the roof.

The system is mounted on familiar roofing battens over Tyvek on conventional roofing timbers. Once the frame is installed the modules are inserted, connections made, and cap strips riveted on to secure the modules. A gasket ensures that water will not seep between the modules and the frame. Using this patented framing system and PV Systems' experienced installers led to a straightforward installation with the pace of work increasing as it progressed.

### 3.2 Roof-mounted systems

Overall 17 sites installed roof-mounted systems, most of these (15) were on pitch roofs, with the remaining two on flat roofs.

#### 3.2.1 Pitch roof

Fifteen sites within the PV DFT had pitch roof installations which were roof-mounted. Six of these used the UniStrut framing system with diamond fasteners holding laminates in place (as developed for the BP Solar "Sun-in-a-box" system). Another used the UniStrut framing system with modules directly bolted to the frame work. Five used the SolarMarkt AluTec system (with a variety of roof fixing methods) and the final three sites used three different systems: the Intersol mounting system, the Naps Solar Roof (NSR) retrofit system and PV Systems' PVS3 "over tile" system.

##### 3.2.1.1 UniStrut framing system with diamond fasteners

The system employed uses unframed PV laminates mounted on a steel channel UniStrut matrix held in place by roof hooks. The matrix comprises base structural rails, used either horizontally or vertically (Figure 20 and Figure 21), secured to the rafters with solar roof hooks (fastened by coach bolts) and laminate mounting rails.



*Figure 20: Using scaffold tower to install the “Sun-in-a-box” system: laminates portrait, base structural rails horizontal*



*Figure 21: “Sun-in-a-box” system: laminates landscape, base structural rails vertical*

The laminates are fixed to the matrix using the BP Solar “diamond” fastenings. This is illustrated in Figure 22 showing the channelling, laminate “diamond” fixings and the roof hooks utilised. The rails are of a ‘U’ section channel UniStrut; 41x41 mm for horizontal and 41x21 mm for vertical. The laminates are held in place with diamond fasteners and an aluminium edge frame with mitred corners completes the installation. This improves the colour of the edge, hides the channelling, and reduces the apparent height of the array above the roof.



Figure 22: Looking along the PV array as it is being installed, showing the steel channel and the “diamond” fixings

For one site in Scotland rather than battens above felt, there is sarking (ply and felt) under counterbattens under battens (see Figure 23). This is because Scottish practice is different to English: it requires greater wind and infiltration resistance. The solar hooks were therefore, made to different dimensions. A longer fixing bolt for the hooks was also required.

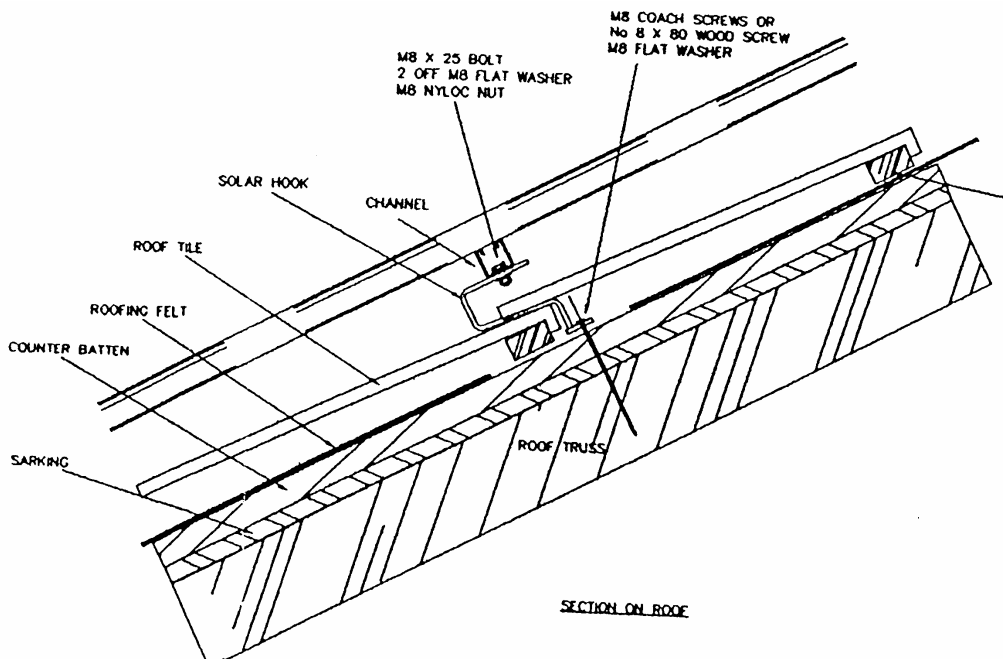


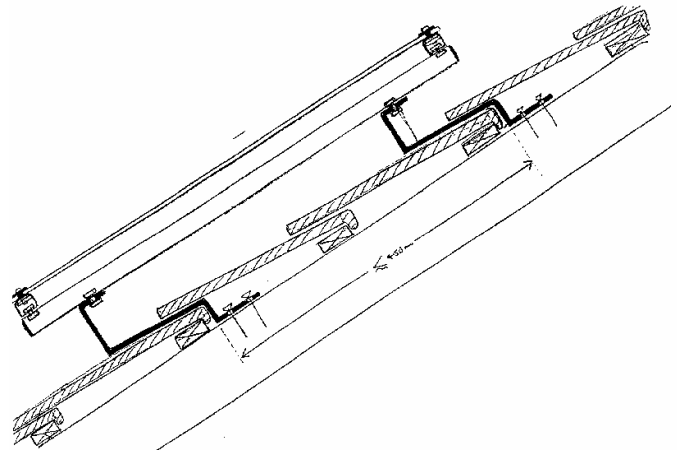
Figure 23: Section of Scottish practice roof, mounting hook and UniStrut module frame (BHA)

### 3.2.1.2 UniStrut framing system with modules bolted on directly

One of the earlier sites used the UniStrut steel channel system described earlier but with modules bolted directly to the framework before installation on the roof. This site actually employed two types of fixing systems for the framework. A proprietary system by Klobber and one using roof hooks. The Klobber system consists of a bracket which is already attached to a plastic tile, designed to be the same as one of their proprietary profiled roof tiles, it transmits the weight directly to the battens (see figure 24).



*Figure 24: Klover Tile with Special Attachment (picture Klover)*



*Figure 25: Bracket design for flat concrete tiles*

The roof hook system was used for properties with thinner flat concrete tiles. Figure 25 shows the bracket design and the way they attach to the rafters under the tiles. Note that these are screwed to the rafters rather than hooked via the tiles to the battens, which gives stronger fixture. On the other hand they cause the tile to be lifted up slightly on their lower edge. There was concern that this would decrease rain and wind penetration properties of the roof, but under observation this was not found to be a problem. The bracket also had to be strong enough to resist bending under the weight of the array, as this would otherwise have put pressure onto the tile below.

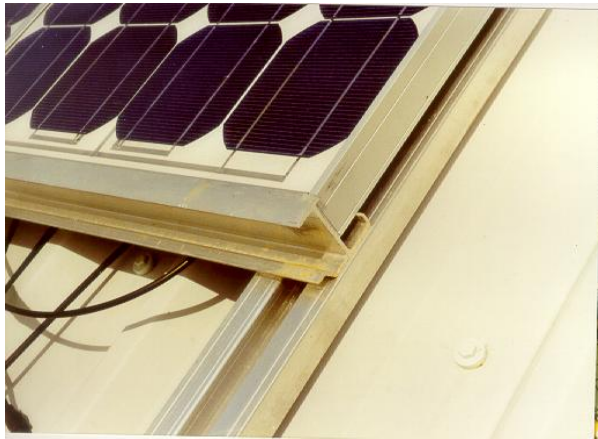
Problems were experienced when it became clear that the Klover tile did not fit with the existing tiles used and that mounting tiles had to be specially manufactured and drilled for the Klover brackets to be attached. This indicates the need to ensure that any proprietary product does fit in with conventional systems. The ideal sequence of installation is to fix the modules to the Unistrut first, and then mount this onto the roof brackets. Fixing the Unistrut first and then the modules is difficult because of poor access to the bolts. Therefore the design of the frame mountings should consider this, in terms of their shape and proximity to the edge of the array.

Other problems encountered on this site were due to the roofing timbers being warped and settled making it difficult to attach the framework and locate the modules squarely and evenly. Also the original design had to be altered after a detailed site survey, as the modules were located high on the roof. The original location allowed for good visual integration and minimised potential shading. The structural engineer however concluded that the extra loading on the roofing members would be better placed lower down where they are shorter, so the bending moments would be reduced. The lessons learnt here, particularly for one-off retrofit installations, are that it is wrong to make assumptions about the strength or squareness of old roofing timber, and that European products may not fit in a British context.

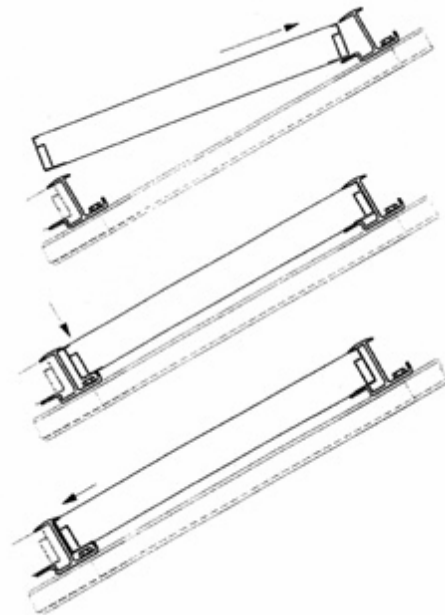
### 3.2.1.3 SolarMarkt AluTec system

The Alu-Tec system consists of a simple aluminium frame fitted on the roof, whereby the frame holds the PV module in place. The frame is made from proprietary aluminium sections and the overall system comprises roof rails and extruded module mounting rails. With the AluTec system, the structural rails secured to the roof are installed vertically. The large cross section enabled cables to run through it if desired.

The extruded module mounting rails, AluTec, are installed horizontally (Figure 26) with sufficient clearance to enable the modules to be lifted in (Figure 27). The modules are pushed up to the top rail and lowered to rest on the lower rail; the flange of the rails keeping the modules in place. The spacing of the horizontal AluTec rails is therefore critical to enable the modules to fit in easily, but also to securely hold the modules once they are in place. On one site, carefully cut wooden ‘templates’ were made and used to correctly space the rails until the bolts were tightened. This means the modules should be easy to remove by lifting and tilt outwards the lower edge enabling easy exchange if required.



*Figure 26: Construction of the frame*



*Figure 27: Illustrating the mounting method for modules in the AluTec system*

Silicone sealant is used between the modules and their frame to prevent any rattling caused by wind, and the whole frame is designed to accommodate thermal expansion and contraction. The end panels are drilled and secured using pop rivets, enabling easy removal if needed by drilling the rivets out. Once the panels have been fitted, the rails are usually trimmed to exact length using a diamond toothed saw.

The verticals can be fixed to the roof in a number of ways, with roof hooks being the most common method. Common fittings used to attach the roofing sheets (metal profiled sheets) were also found to be suitable and one project found this ideal to avoid any likelihood of water or wind penetration due to the PV. On another site a UniStrut mounting frame was first attached to roof hooks then the AluTec system was fixed to the UniStrut.

### 3.2.1.4 Intersol mounting system

This system uses steel roof-hooks which are fixed to the roof under-structure which requires the removal of existing tiles. Following this the tiles are replaced again and aluminium profiles fixed to the roof-hooks into which the PV modules are fitted and secured with module clamps (Figure 28).



*Figure 28: The PV array mounted on the pitch roof using the Intersol mounting system*

For the PV DFT site the installation was completed by experienced PV installers with the support from roofing sub-contractors. During the installation there was some damage to the existing roof structure which was anticipated and had been identified within the initial risk assessment. In addition the PV installer was able to highlight other roof repairs required at the time (unrelated to the PV installation) and these repairs were implemented whilst the scaffolding was erected. Another factor worthy noting is that one contractor asked to quote on roof works would not do so because of the perceived risk due to the PV installation.

### 3.2.1.5 Naps Solar Roof (NSR) retrofit system

The NSR system comprises of a slide in mounting system utilising vertical extruded aluminium sections with a special profile which hold the modules in place. The modules slide in, either from the top down or the bottom up and are secured by the flanges of the extruded section. A stop bolt and shim prevents the modules from sliding out. The profiles are mounted on horizontal support tubes, 'D' section, which are fixed to the roof hooks (various designs available for different roof constructions which will be pre-drilled in the factory after a site survey) using fully adjustable mountings to compensate for variations in the roof. The frame is first assembled on the roof and then the modules are easily slid into the profiles, completing the electrical connections at the same time.

On the PV DFT site which used this mounting system, Figure 29, the first PV array was mounted by PV installers working from two scaffold towers placed side by side. Once the procedures for mounting the array had been verified from the first installation, one experienced PV installer then installed a second PV array working with two sub-contractors. Both of these sub-contractors had previously worked in the fitting of solar water heating

systems and so were experienced in working on roofs and in loft spaces. The sub-contractors then installed the remaining 14 system arrays.



Figure 29: The Naps NSR retrofit system

**3.2.1.6 PV Systems’ PVS3 ‘Over- Tile’ mounting system**

Within the PVDFT the PV Systems’ PVS3 ‘Over- Tile’ mounting system was fitted on top of a profiled sheet metal roof (Figure 30). The Decktite fittings employed supported a 75mm galvanised steel section, in order for the rails to stand proud of the contours forming the vertical rails. The horizontal rails are 41mm galvanized channel section, similar to Unistrut. The laminates are held to the channel with diamond fasteners.



Figure 30: View of the installed modules on the roof top

### 3.2.2 Flat roof

Two sites within the PV DFT installed PV systems on flat roofs. One used the Econergy ConSole system and the other, the SolarMarkt AluStand System.

#### 3.2.2.1 Econergy ConSole system

This system utilises probably the simplest installation method of all systems summarised so far. The PV modules are bolted to Econergy's 'ConSole' plastic trays designed for installation on flat roofs offering six different ConSole sizes. The advantage of this type of installation is that it can require no or only limited penetration of the building fabric or the roof structure, often allowing cables to be run through existing/new ventilation shafts into the building. Approximately 75 kg of loose ballast is filled into each console, with the PV module bolted directly to the top. A key issue is to ascertain that the flat roof can withstand this loading. The ballast ensures the modules stay fixed, although since the consoles are not bolted down they can be moved relatively easily for roof maintenance.

At the PV DFT site the whole mechanical installation was completed using unskilled labour, i.e. filling the consoles with ballast (using a shovel and wheelbarrow) and locating them at the top of the parapet wall/concrete roof junction, hence there was not an issue with the additional roof load this involved. In buildings with weaker structures and wider spans such as a 1960s system built school for example, careful assessment of the loading may be required.

Figure 31 shows the consoles installed on the parapet wall with the stone chipping filling for ballast. Note the flanges to the console edges for interfacing to a wide variety of module types. The material is easily drilled to accept fixing bolts. Each module was secured to the console using 4 M6 bolts and washers.



*Figure 31: Ballast levelled off, dc cabling installed and irradiance sensors for monitoring equipment installed (Hockerton Housing Partnership)*

### 3.2.2.2 SolarMarkt AluStand System

The SolarMarkt AluStand system is derived from the AluTec system used for roof-mounted layouts as discussed earlier. The AluStand system is specifically designed for supporting tilted modules on flat roofs. Essentially the system uses horizontal rails of AluVer 41 secured to concrete flagstones that form ballast on the flat roof. The modules are slid between horizontal rails, one module high. This assembly is bolted to the roof rails with vertical uprights using sliding bolts within the rail extrusion. Some compensation for variable heights can therefore be achieved. Figure 32 shows the installed PV system on the flat roof.

The PV is arranged into three banks approximately 2.5m apart. The rails are secured to 150mm concrete slabs, each 600mm square. This size was specified following detailed structural engineering calculations to simulate the worst case of wind uplift expected at the site.



*Figure 32: The installed frame-mounted PV system*

### 3.3 *Special/bespoke systems*

Of the final two sites one used a façade integration system by PV Systems and the other incorporated three different styles, all with bespoke integration methods.

#### 3.3.1 **Façade Integration**

The façade integrated system (FIS) used by the installer (PV Systems) comprises main rails and cross rails from extruded aluminium sections. The module laminates are fitted with an EPDM gasket around the edges before installation to protect them and form a weatherproof seal when installed. The façade frame was pre-assembled and checked for alignment before fitting to the building (Figure 33). The structure was then clamped to the battens on the building. The laminates are installed on the cross rails and held in place with a cap strip secured by rivets to the cross rails, compressing the gasket and providing a seal.



*Figure 33: Façade Integrate System in place using some “dummy” PV panels where there is increased shading*

#### 3.3.2 **Bespoke systems**

The last site within the PV DFT has the most complex design, not just because of the fact of three different styles of PV integration, but because of the bespoke integration methods. There are two different types of double-glazed unit, those mounted as the roof of the conservatory and those for the walls (Figure 34). The structural and weathering demand of the roof application required a metal aluminium frame, while those of the walls required a wooden frame.



*Figure 34: The modules mounted on the roof and wall of the conservatories*

Following are the steps taken during the acquisition and installation of the roof double-glazed units:

- Sealed double-glazed units manufactured to a specified size to fit the building design.
- They are mounted into the aluminium frames by Vital. Special attention is given to cable routing to make their ultimate installation more straightforward.
- Secure storage on site.
- Roof sealed double-glazed units installed by double-glazing installation contractors.

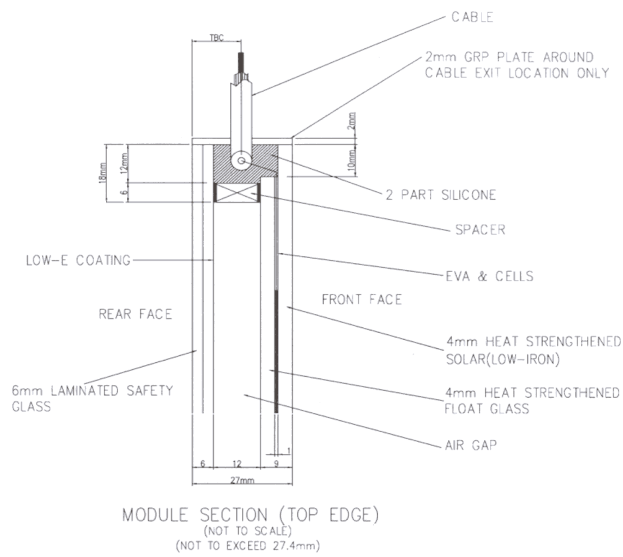
The wall double-glazed units were assembled into wooden frames on site by the framing company contractors. No special skills were required to fix the pre-fabricated units. The double-glazing installers were given some brief instructions and moved the panels about very carefully at first. However they realised quickly that they were no different from other double-glazed units other than being more expensive to replace in case of breakage. This very smooth installation was the result of careful planning and design, making sure cables are at the exact length required and include MC connectors in order to allow unskilled personnel to make the electrical connections.

Figure 35 shows the plug and socket connectors at the ends of wires coming from the frame. These male and female connectors can only be connected to the correct cable from the adjacent panel.



*Figure 35: Once plugged together, the plug and socket connectors will be concealed and accessible*

The cross-section in Figure 36 shows the design of the double-glazed units for the rooflights integrated into Vitral frames. Notice the laminated safety glass on the inside. The cells themselves are between two layers of glass and the cable exit is via a cavity filled with two part silicone.



*Figure 36: Double glazed unit*

## **4 Lessons learnt**

This section reviews lessons learned at all stages of the design, construction and PV installation process. The lessons learnt have loosely been classified in three categories: communication, site/location and good practice. Although these are already important issues within the construction industry in general it clearly has a heightened importance when introducing a new technology such as PV into the built environment.

The list of lessons learnt below summarises the various problems encountered on different sites. They were captured in various stage reports by project teams and face to face interviews during site visits.

### ***4.1 Communication***

Communication has remained a key issue within the DFT programme. Lessons from the programme indicate that projects should:

- Include the PV system in the conception/design process as early as possible, this will ease the building integration and minimise costs;
- Consider the responsibilities at an early stage of the contract;
- Ensure that efficient and effective contractual arrangements are in place;
- Ensure that the PV supply and installation is correctly scheduled into the main build programme and that in general the logistics are well planned;
- Ideally have one organisation or person overseeing the whole project;
- Set in place contingency plans that can be adopted should something go wrong;
- Make sure that there is good co-ordination between PV suppliers/installers and other professionals/trades;
- Ensure that the project has continuity of contract workers and training on handover;
- Always aim to complete the installation before the properties are occupied, access is a major issue and can cause substantial delays and add costs;
- Confirm the warranty arrangement, i.e. module replacement at no extra cost should breakages occur at any of the installation stages
- Ensure that the DNO is notified; the contractor responsible for this should be defined at the start of the project (usually the PV installer) and, if appropriate, that there is adequate and effective liaison with the DNO and electricity supplier;
- Consult with householders to secure positive support for the installations, explaining the benefits of PV systems and available support to help with exporting electricity and obtaining the associated financial benefits;
- Stress that there will be access requirements and other site disruptions, i.e. scaffolding
- Ensure clear and easy to understand handover documentation should be provided outlining regular visual checks, general problems and solutions including contact details for more serious concerns;
- Provides and easy to understand and accessible system display, i.e. showing instantaneous power generation, should be part of the overall PV system.
- PV companies should disseminate the aspects mentioned above to everyone within the build team as well.

### ***4.2 Positioning and location***

Under this heading lessons learnt all relate to the positioning of the PV systems and/or location of the actual installations. The most important considerations are summarised below:

- Position the array on the roof to take account of loading, particularly for older, refurbished properties;
- Do not make assumptions about the strength of existing roofs. If there is any doubt or concern a detailed structural survey should be carried out by a structural engineer as part of the project feasibility work;
- The chosen mounting system should have some flexibility, i.e. roofing layout may have changed during construction; if there are any doubts regarding the layout of the roof structure a system that offers maximum flexibility is best. Similarly in older buildings it should not be assumed that roofing timber is necessarily square nor that it has retained its squareness over time;
- Ensure that products are suitable for the context in which they are to be used;
- Ensure that products/systems adhere to the relevant regulations/practices, local or national i.e. variation in building regulations;
- Ensure that installations comply with all of the appropriate standards;
- Check the availability of replacement roof tiles in case existing ones get damaged during installation;
- Consider allowing increased ventilation of the PV panels/tiles, if feasible, and the effect that this will have on the installation process;
- Consider safety issues as installation methods for PV tiles are different to conventional tiles and specific safety issues of working with DC electricity need to be considered for these systems;
- Check electrical continuity of the PV modules/tiles on installation;
- Confirm the supplier/installer has taken special measures to mitigate against breakages, i.e. suitable protection of edges and surfaces of laminates until installation;
- Consider site/component security and insurance;
- Mitigate against vandalism and theft, in case the properties are not occupied or the modules are stored on site during the installation;
- Check the metering arrangements as some pre-payment electricity meters do not allow export of electricity and can be damaged by attempted export;
- Consider specific location based concerns;
- Site Balance of System (BOS) components, i.e. inverters etc in accessible areas where they do not pose a nuisance, i.e. inverters can make a slight humming noise and might not be suitable for certain living spaces, particularly relevant in refurbishment projects.

### ***4.3 Good practice***

The following lessons learnt were classed as “good practice”, however some are considered as essential in that they relate to the requirements of specific standards.

- Appropriate labelling, according to the standards, must be put in place, this is a key issue for DNOs;
- Ensuring standards are applied and adhered to;
- Standard H&S procedures for building construction must be adhered to;
- PV installer might have to comply with a Local Authority’s H&S requirements in order to become an approved contractor;
- Risk assessments and method statements must be supplied by the PV contractor;
- Consider that the roofing company might not offer an extended warranty if PV is integrated, this can effect roof refurbishment and new roofs;
- Installers should always aim for the highest quality of general installation, e.g. wiring should be clipped and tidy;
- Ensuring that good practice is maintained with respect to PV installations generally;

- Short and precise handover documentation;
- Make sure appropriate customer services are in place.

#### **4.4 Summary**

Communication has remained a key issue within the DFT programme. Its importance cannot be over stressed as most projects experienced minor problems, and quite a few major ones, due to poor communication, leading to delays and additional costs. This also relates to the need to making sure that different trades understand each others specific requirements, calling for better dissemination between the PV and construction industry, as well as other associated organisations or clients.

Understanding of PV systems, their layouts and the operational requirements of the component parts, including DC wiring and BOS equipment siting, is crucial to effective and efficient installation as well as operation. Providing information and training to project teams, householders, caretakers etc. is an important step in this process. Experience throughout the DFT has shown that it is crucial for inverters and displays to be easily accessible, as this will avoid any follow on problems when it comes to maintaining the system. Therefore effective layout combined with precise and easy to understand handout documentation will make monitoring of the system operation and subsequent maintenance easier. This also highlights the need for better customer services, making sure client and householder demands in regards to installation and operation are understood and met. One needs to keep in mind that most householders or other maintenance people (caretaker) are new to the operation and maintenance requirements of PV. All of the issues mentioned here have been addressed within the PV DFT Good Practice Guides – Part 1 and 2 (see section 9.1.5).

## 5 System costs

This section summarises system costs as outlined in the project teams' procurement reports. Project costs are expressed in £/Wp and are broken down into module and electrical installation costs, hardware costs (inverter and module), monitoring and project management costs. An overview of all the costs for the different sites is given in Figure 37 and Table 1. The total costs are shown in three ways: total overall, total excluding monitoring costs and total excluding both management and monitoring costs.

It should be noted that due to the nature of the DFT the monitoring and management costs are significantly more expensive than could be expected for general PV projects. This is due to the detailed monitoring requirements outlined in section 7, which also required additional management time, and the reporting requirements. Defining the exact figures these requirements added is beyond the scope of the programme but can be deduced somewhat when looking at general monitoring costs discussed later.

All 33 sites (some projects covered more than one site) were analysed and broken down into different installation types: retrofit modules on frame, retrofit tile integrated, new-build modules on frame, new-build tile integrated and new-build roof-integrated modules.

### 5.1 System and installation costs

Figure 37 illustrates the accumulative cost breakdown for the different installation types. These are retrofit modules on frame (sites 1-8), retrofit tile integrated (sites 9-10), retrofit laminates (sites 11-13), new build modules on frame (sites 14-19), new build tile integrated (sites 20-26), new build roof integrated modules (sites 27-29) and new build laminates (sites 30-33). One can see that costs are fairly constant within the different installation types with a number of peaks. Most of these peaks seem to be the result of varying installation costs, for example within retrofit sites module costs are fairly constant between sites 1 to 8, however sites 1 and 2 show much higher module installation costs. Peaks for sites 9, 14, 17, 21 and 25 seem to be the result of higher module costs, although the exact breakdown of module costs was better in some projects than in others. For example some projects may have included mounting systems in the module costs.

Also most of the retrofit sites (1 to 13) have higher than average monitoring costs, which is due to the monitoring being an "add on" rather than an integrated process. Much more effort and physical man days are required to add monitoring into an existing building than a new-build, where monitoring can be included at the design stage.

Looking at Table 1 shows that the deviation figures for hardware costs (i.e. inverter and module costs) are around 30% or below for nearly all the different installation types with only one exception. This shows that hardware costs were relatively constant between all sites. In contrast both module and electrical installation cost deviations are less homogenous, with deviations around or above 30%. These varying installations costs are to be expected and should become more homogenous over time, especially within the different installation types. These variations are also illustrated in Figure 37.

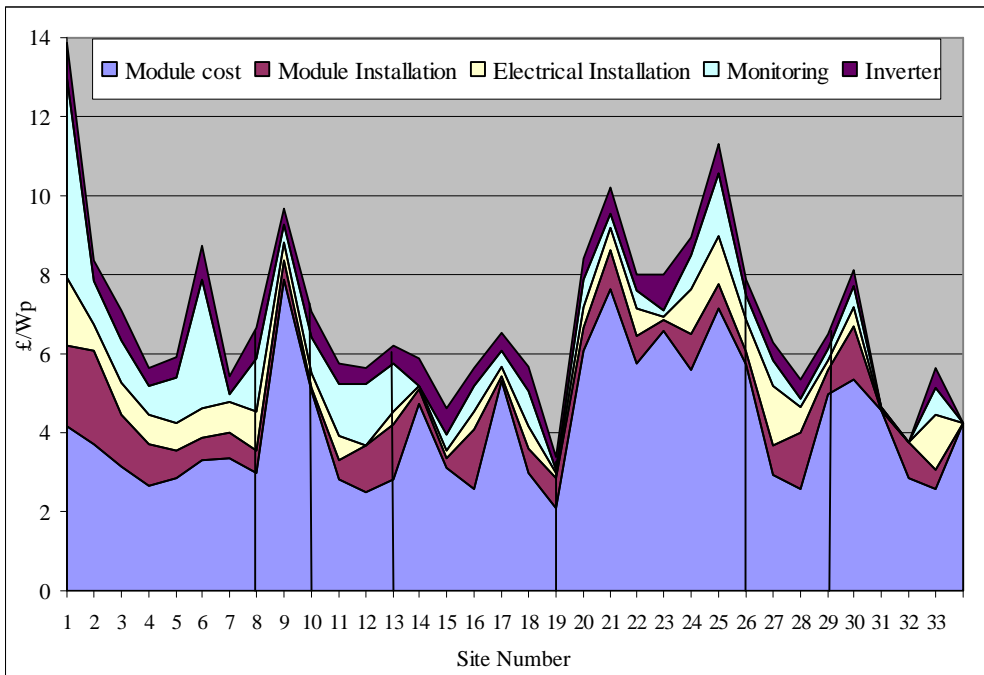


Figure 37: Accumulative cost break-down for components and installation per site

Overall new build frame mounted projects incurred the lowest total costs, at an average of £5.11/Wp excluding management and monitoring costs (Table 1 and Figure 38). The highest average cost was for new build tile integrated systems (£8.28/Wp), the figures shows that this can mainly be attributed to the use of the more expensive solar tiles. These also generally have higher electrical installation costs since wiring will typically take longer compared to modules. These are smaller modules so more connections are required to be made for the same size of system.

Figure 38 again illustrates how the cheapest option was new-build modules on frame and higher monitoring costs for retrofit systems. It also shows that new-build and retrofit laminate costs are comparable to frame-mounted modules.

Cost Analysis/ £/Wp	Module Installation	Electrical Installation	Monitoring	Inverter	Module	Management costs	Total Costs	Total excl. monitoring	Total excl. monitoring & management
<b>All sites (33)</b>									
<b>Average</b>	0.68	0.56	0.73	0.50	4.25	0.56	7.28	6.67	5.98
<b>Min</b>	0.07	0.06	0.10	0.31	2.09	0.02	3.57	3.45	3.27
<b>Max</b>	2.34	1.70	5.06	0.91	7.88	2.41	14.02	11.64	9.83
<b>Average deviation</b>	0.40	0.30	0.60	0.14	1.43	0.53	1.89	1.69	1.44
<b>Average deviation/average</b>	59%	55%	82%	28%	34%	95%	26%	25%	24%
<b>Retrofit modules on frame (11)</b>									
Average	1.02	0.72	1.64	0.60	3.12	0.47	7.67	6.03	5.57
Min	0.47	0.33	0.23	0.39	2.47	0.02	5.43	4.09	4.08
Max	2.34	1.70	5.06	0.89	4.16	1.56	14.02	8.96	8.80
Average deviation	0.49	0.25	0.92	0.16	0.38	0.49	1.81	1.15	0.98
Average deviation/average	48%	34%	56%	26%	12%	105%	24%	19%	18%
<b>Retrofit tile integrated (2)</b>									
Average	0.27	0.41	0.67	0.55	6.47	1.64	10.01	9.34	7.70
Min	0.07	0.36	0.46	0.43	5.07	0.86	7.92	7.04	6.18
Max	0.48	0.45	0.88	0.67	7.88	2.41	12.10	11.64	9.23
Average deviation	0.20	0.04	0.21	0.12	1.40	0.78	2.09	2.30	1.53
Average deviation/average	74%	11%	32%	23%	22%	48%	21%	25%	20%
<b>Newbuild modules on frame (11)</b>									
Average	0.62	0.35	0.38	0.39	3.74	0.40	5.89	5.51	5.11
Min	0.10	0.08	0.10	0.31	2.09	0.10	3.57	3.45	3.27
Max	0.62	1.38	0.38	0.72	5.35	1.45	8.95	8.40	6.19
Average deviation	0.36	0.28	0.38	0.17	5.35	0.49	1.28	1.17	0.97
Average deviation/average	58%	80%	100%	44%	143%	120%	22%	21%	18.99%
<b>New build tile integrated (7)</b>									
Average	0.63	0.72	0.67	0.58	6.35	0.73	9.69	9.01	8.28
Min	0.32	0.06	0.16	0.40	5.60	0.13	7.99	7.40	7.27
Max	0.95	1.22	1.58	0.91	7.64	1.63	11.84	11.46	9.83
Average deviation	0.20	0.29	0.32	0.16	0.65	0.59	1.23	1.00	0.85
Average deviation/average	31%	40%	47%	28%	10%	81%	13%	11%	10.28%
<b>Newbuild roof integrated modules (2)</b>									
Average	1.07	1.09	0.43	0.46	2.76	0.31	6.12	5.69	5.38
Min	0.75	0.66	0.23	0.46	2.59	0.62	5.95	5.66	5.11
Max	1.40	1.52	0.63	0.46	2.92	0.62	6.29	5.73	5.66
Average deviation	0.32	0.43	0.20	0.00	0.17	0.31	0.17	0.03	0.28
Average deviation/average	30%	40%	47%	0%	6%	100%	3%	0.6%	5.17%

*Table 1 – Comparative cost analysis showing the average deviation of costs for all sites, as well as average total costs (£/Wp) by installation type. The minimum figures do not take account of ‘zero’ values in order to avoid biasing the averages. The ‘Average deviation/average’ figures give a comparison of the variation from the average for all types of cost.*

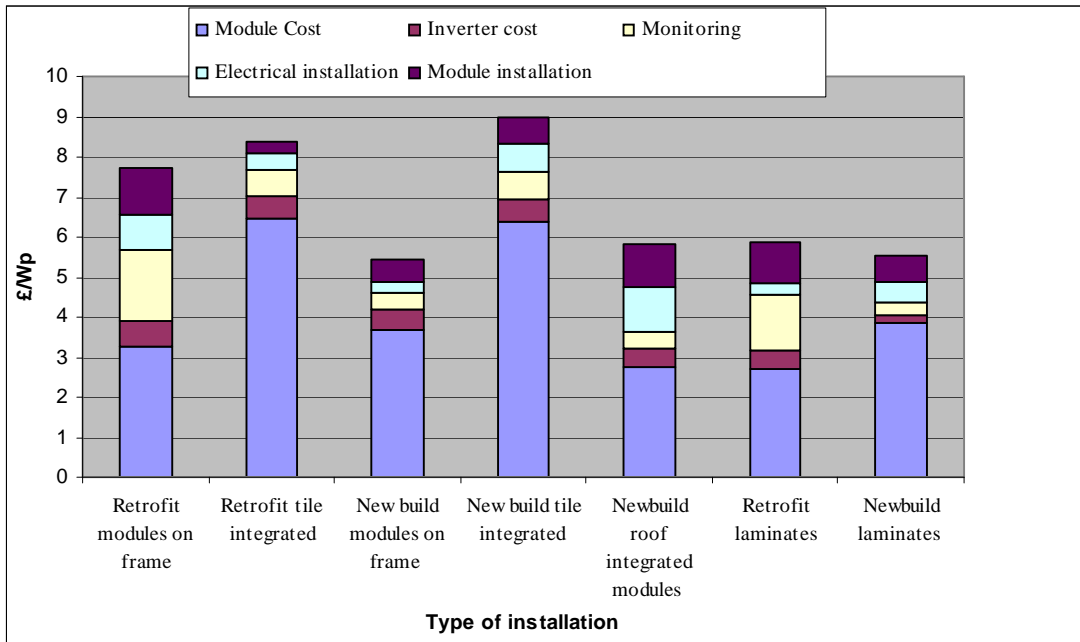


Figure 38 – Cost break-down for components and installation for different types of site

Figure 39 illustrates the breakdown of costs for all sites into the different elements, indicating that equipment, installation and monitoring make up 68%, 20% and 12% respectively. An ordinary householder wishing to meter the electricity generated by their PV system would be expected to spend substantially less than 12%, probably around £100 including meter costs and installation. Furthermore quite a number of sites incurred additional costs not originally budgeted for, e.g. additional construction work, correcting monitoring errors etc. These have not been included in this analysis, as they were outside the PVDFt specifications and had to be paid for by the Project Teams themselves.

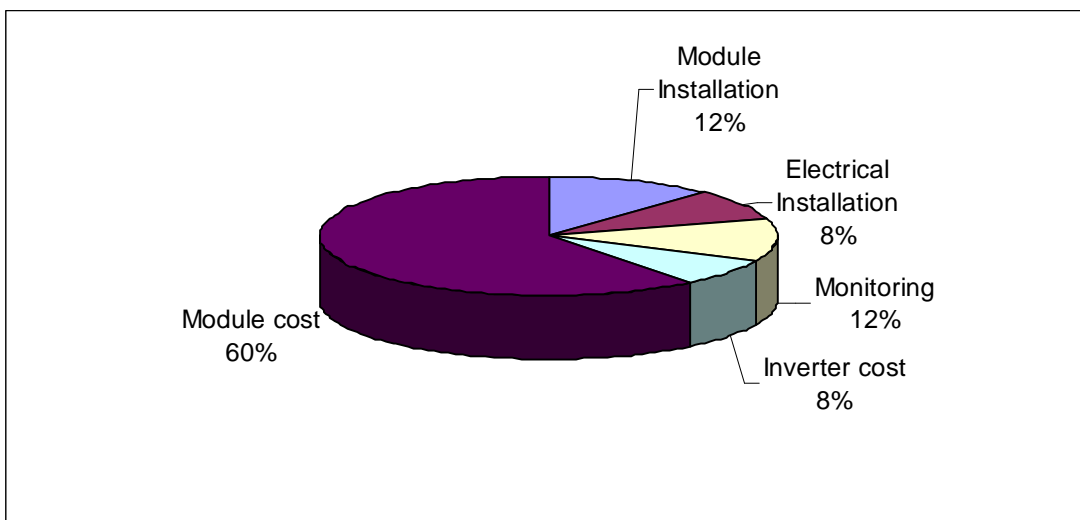


Figure 39: Average component and installation costs for all sites

## 5.2 Electricity costs per kWh

Most of the DFT sites have successfully provided over a year of data (section 8). Using these figures for 25 sites, the average cost of electricity per kWh was calculated, based on a PV system lifetime 25 years. The result gives an average of 47.5p/kWh, a minimum of 20.9p/kWh and a maximum of 184.7p/kWh. Out of these 25 sites 18 actually came out at below the average. Taking out the two most expensive sites, which by coincidence were also under-performing, both the average and maximum are reduced to 39.1p/kWh and 77.8p/kWh respectively.

This is well above current electricity prices. However, with energy costs rising and PV system prices falling the economics of PV are continuously improving. In addition general electricity prices do not take account of the decentralised nature of PV, meaning grid distribution losses are limited as the electricity is basically used at source. This issue is meant to be included within ROC prices or subsequent buy-out contracts, however how far this has happened in the UK is beyond the scope of this programme.

## 5.3 Cost comparison

It is interesting to compare these costs with findings of other PV installations in the UK. Analysis of the costs encountered in the Major Demonstration Programme (MDP) show that the average costs for retrofit systems for Quarter 12 (the most recent) were £6.34/Wp and for new build installations £7.40/Wp. It should be noted that these costs also include management costs.

The average costs within the DFT for retrofit sites at £8.03/Wp (£5.90/Wp) is much higher whereas the new build sites at £7.24/Wp (£6.25/Wp) is actually lower. The figures in brackets give average costs excluding management and monitoring expenses. This would indicate that retrofit projects have actually realised higher cost reductions than new-build projects. However, a direct price comparison between the two programmes is not possible, due to the different approaches of gathering and analysing data, as well as the different nature of the projects in terms of scale.

Table 2 shows that most of the cost elements of installed PV systems have fallen during the reporting periods covering 2001 to 2003, apart from monitoring. This trend seems to continue within the MDP, where average installed costs of £7.80/Wp in Quarter one have fallen over the last three years to £6.41/Wp. Please note that Table 2 shows average costs of the sites covered in the respective report and will therefore not correspond to findings in Table 1, which combines costs of all DFT sites.

Cost Analysis/ £/Wp	Costs in/ published in	Module Installation	Electrical Installation	Monitoring	Inverter	Module	Total	Total excl. Monitoring
Average 1st report	2001/2002	1.00	0.51	1.42	0.59	4.4	7.47	6.33
Average 2nd report	2002/2003	0.72	0.92	0.72	0.53	4.30	7.20	7.61
Average 3rd report	2003/2004	0.69	0.52	1.01	0.47	4.14	6.83	5.82

Table 2: Cost comparison over the course of the PV Domestic Field Trial. Showing average costs in £/Wp and the percentage increase or decrease compared to the previous year.

## 5.4 Summary

Overall the trend of decreasing costs is an indication that the PV market has gained

confidence and moving towards a more streamlined process. Furthermore significant savings can be achieved when integrating PV frame mounted systems into new build, since the costs of site works, storage and scaffolding are shared by other construction works. Good planning and communication can help to further reduce costs (section 4).

## 6 Survey results

As part of the PV DFT, two surveys have been carried out, the Post Occupancy and the Post Selling Survey. This section presents the analysis for both surveys, summarising the results and hence assessing the impact on those involved in the programme. It also considers the implications from these findings for future projects/installations in the domestic setting and for the PV industry as a whole.

### 6.1 Post selling survey

A developers' questionnaire, the Post Selling Survey, was designed to gather feedback from each development site via the project team leader (Appendix 1). Initially it was aimed at private developers in order to evaluate their acceptance level, impact on house prices and uptake of PV by the building industry. It was however extended to include public sites in order to establish their role as market driver with their own specific agenda: Private developers are mainly profit driven, public housing providers aim to offer affordable housing. PV offers them an opportunity to reduce tenants' electricity bills. In contrast private developers' incentives to install PV will be based on whether they perceive PV to offer added value to the property or on evident customer demand. The questionnaire was used for both groups, public and private, establishing their views on ease of installation, added value, end user perception, aesthetics, marketing value and future demand. To establish further understanding on perceptions of PV systems, other interviews took place with private developers and housing associations who had not participated in the PV DFT.

### 6.2 Profile of developers and householders

In total 27 of the 28 project team leaders returned their completed questionnaire. Figure 40 below shows the percentage of each developer type taking part in the project. As part of the survey amongst developers not participating in the PV DFT it emerged that the majority using PV products can be found within the public sector. Four groups out of 49 interviewed had actually used PV previously of which three were Housing Associations. Therefore the proportion of private versus public PV developments within the PV DFT roughly reflects the PV market in this sector. However, publications by the ODPM show that the number of households that own their own home has increased substantially over the last 50 years to over 70% in 2003 [<sup>2</sup>]. This places the biggest potential for PV uptake within the private housing market.

Figure 41 shows the building type and the occupants' description for each development. Out of the 27 developments the majority of the properties are occupied by low income, elderly or disables residents. It is only those developments with houses that have a higher proportion of the occupants being described as earners of a general nature

---

1. <sup>2</sup> Office of the Deputy Prime Minister (ODPM): "Sustainable Communities: Homes for All - Chapter 2 Trends and Challenges"; Jan 2005, [http://www.odpm.gov.uk/stellent/groups/odpm\\_about/documents/page/odpm\\_about\\_034295.hcsp](http://www.odpm.gov.uk/stellent/groups/odpm_about/documents/page/odpm_about_034295.hcsp)

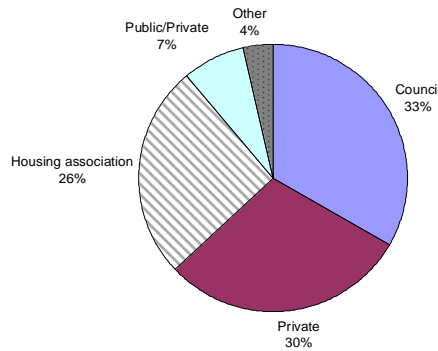


Figure 40: Description of Developers involved in PV installations. (n=27)

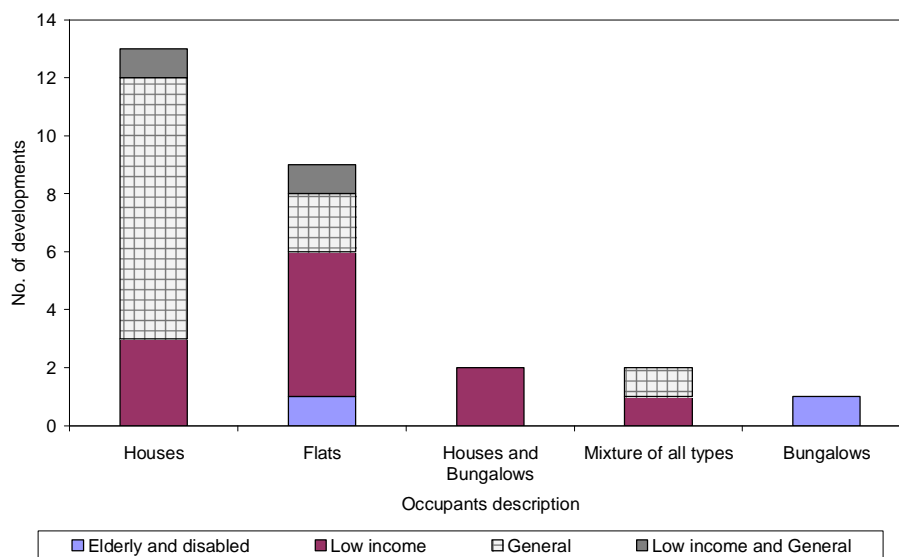


Figure 41: House types and occupants description (n=27)

### 6.3 Decision to install PV systems

The decision to use photovoltaics within the development was decided mainly by the developer (66%), but Figure 42 shows that installers and energy consultants also played a leading role in realising the use of PV systems on these sites.

### 6.4 Installation issues

Although most of the following issues have already been summarised in section 4 it is important to show how they were spread across the project teams. Sixteen projects did not have any or only minor installation issues (related to the PV system), five had medium problems such as scaffolding being removed too early or lack of communication between the main contractor and PV installer. The remaining five projects experienced severe delays, e.g. roof strengthening required prior to installation or PV requiring testing according to BSI standards. Out of these five three also suffered general construction delays unrelated to the PV systems, e.g. overall planning permission delays.

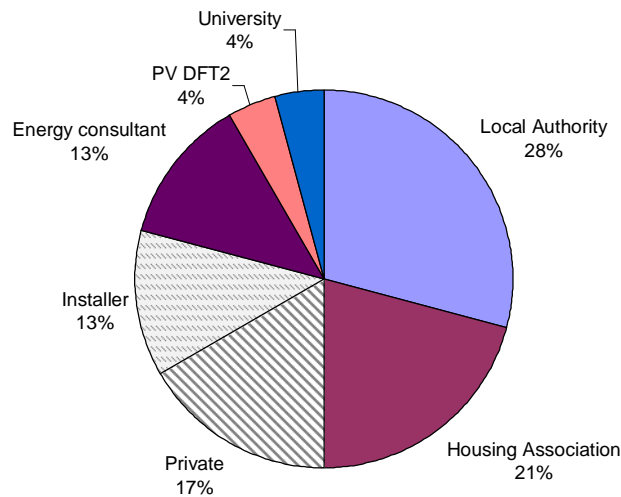


Figure 42: Who led the decisions to use PV systems on the development. (n=25)

Overall problems faced during the installation varied but a common experience was delays suffered either by lack of communication, sourcing replacement equipment or having to train sub-contractors. Two thirds also mentioned having operation issues such as grid connection delays and inverters tripping. Some of the replies also referred to problems with the monitoring system installation and subsequent gathering of data. The monitoring regime is specific to this project and would not occur in standard installations.

One key issue to investigated was whether the project leaders were happy with the supplier and handover documentation. Out of 22 project leaders responding, nearly three-quarters (73%, 16) stated that they were satisfied with the supplier, stating that they received good information and were kept well informed throughout installation process. However it was noted that one or two suppliers were overcommitted and therefore unable to offer all the support required or they were based elsewhere and were therefore unable to respond to issues quickly. Many problems could have been overcome with better communication and commitment between supplier/installer and developer. Developers were also asked how the supplier could have done things better in their opinion to ease the installation process. Responses demonstrate the various issues addressed, such as better project planning and having one contractor in charge of the whole installation.

### 6.5 Impact of PV systems on sale price

Four (15%) respondents (three private developers and one housing association) stated that they had charged more for the houses due to the PV installations. Two gave concrete figures offering following explanations, “more than £3,000 but less than £6,000” and “less than £3,000”. Due to the high demand of properties in general across all developments, there seemed to be no indication that the properties were sold or occupied more readily because of the PV. One also needs to take into account that some sites were already occupied prior to the PV development. Overall there is therefore insufficient information to indicate whether there is demand for this type of property.

Low demand for PV is reflected by the low percentage (6%) of developers having realised PV projects in the non-DFT developer’s survey. Only four out of forty-nine respondents have done so. How representative this is for the overall housing development market is however

beyond the scope of this report.

### 6.6 Visual impact

The appearance of the PV systems was believed to enhance the appearance of the property according to half (52%, 14) the project leaders, and the majority of the remainder (41%, 11) said it made no difference. Two project leaders (7%) said the appearance of the house was less pleasing with PV, but added that it had not been raised as an issue by the occupier (Figure 43). Most project leaders added that the decision to use PV in general would be less favourable if it was felt that it had an adverse effect on the properties appearance.

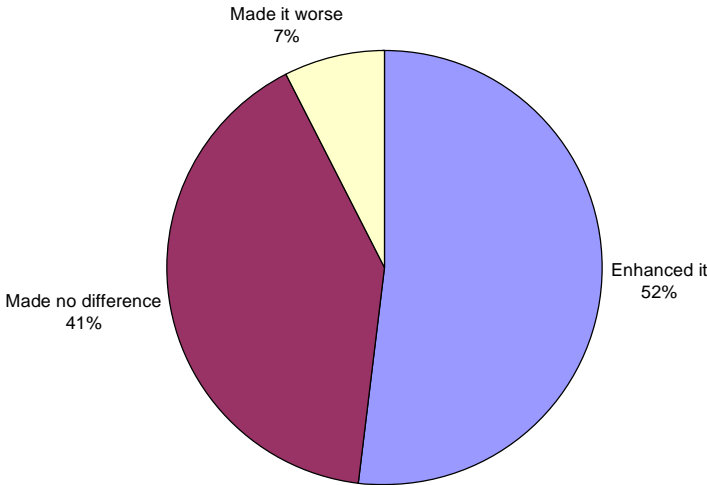


Figure 43: Appearance of PV system on house (n=27).

In contrast only 5% of the developers not involved in the DFT thought the visual appearance was enhanced, whereas 39% thought it was made worse. This different view can only be explained by people involved realising how well PV products can be integrated into the built environment. It also implies that organisation not having been involved consider PV to be an unsuitable building material in regards to aesthetics.

When asked if they themselves had received any comments from people visiting the sites, 57% answered with ‘yes’ they had received comments about the PV systems. All but one stated that these comments were positive, and the other comment was of mixed view: “*not very attractive, but innovative*”. Positive feedback was noted where visitors liked the roof integration and colour match or questions were asked about how much energy they generated. Another positive comment was on how unobtrusive PV was, adding: “*the bluish colour gives interest and sparkles in the sun*”.

### 6.7 Overview and recommendations for the future

In view of future developments project leaders were asked if they would consider using PV systems again and 88% said “yes” they would. Developers seem to like the system in principle, but would like costs to be reduced. Raising awareness and environmental benefits for residents were also mentioned as a positive reason for installing PV in future homes. One

developer showed no interest in using PV in future as there were no apparent benefits to his customers. He did admit that the system had not been in operation long enough to give an accurate assessment at present.

The survey of participants not taking part in the DFT shows that 43 who had not used PV before would consider doing so including 16 which were unsure. Everyone was then asked about their motivation to use PV in the future. Replies are demonstrated in Figure 44 which shows that the majority of “unsure” developers are private, most likely to be driven by legislation (e.g. compliance with Building Regulations). In contrast Housing Associations are more positive about the future integration of PV, being motivated by tenants’ savings on bills and the environment.

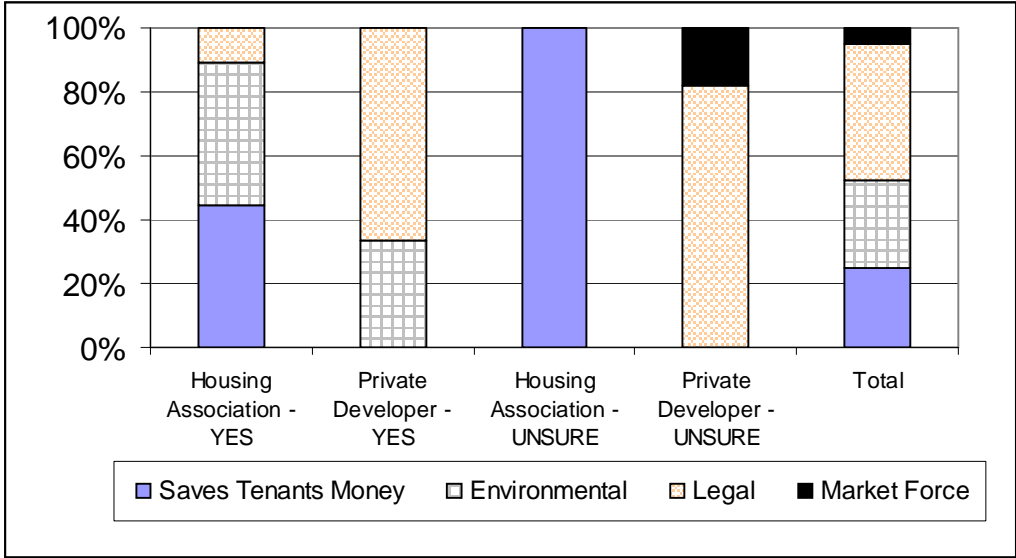


Figure 44: Replies when asked about considering using PV in the future and motivation (n=40)

All but one interviewee within the DFT stated that PV systems should be more widespread, but some comments were added by way of caveats, for example:

- “if the embodied energy required to make them is reasonable”;
- “houses should be their own generator”;
- “in the UK a lot of the PV kit is likely to go on existing build properties, so systems designs are going to have to develop to allow better building integration in my view”.

When asked which of the following best described their feelings about integrating PV in their development they gave following answers:

Quotes given	Response
a) I like it a lot, it looks good and is a great idea, there should be more systems on other houses	17
b) I quite like it although I have reservations about some aspects of it	7
c) It’s OK, there are some aspects that I like about it and some that I don’t	3
d) I don’t like it much, although there are one or two positive aspects	0
e) I don’t like it at all and would prefer not to have used it on this development/these houses	0
Total	27

## **6.8 Summary of Post Selling Survey**

Developers are favourable to PV, identifying costs as the major obstacle. The cost issue is a well known barrier to the uptake of PV and therefore not surprising however participating in the field trials was mentioned to be more complex than anticipated by 68%. It is therefore encouraging, if slightly surprising, to see so many developers (88%) still considering using PV modules in future. It can therefore be said that the field trial helped to shape developers' views to a certain extent and that it contributed positively to the development of the PV market in the UK.

It should also be noted that one of the main reasons why the field trial appears more complex to developers than first anticipated might be related to the monitoring requirement, which is discussed in section 7.

PV is also seen to enhance or at least not alter the appearance of a property. It therefore counteracts common believe that PV modules are "unsightly". This view was supported by 40% of developers not involved in the PV DFT who believed that PV decreases the aesthetics of a property. The construction industry therefore still perceives PV to be aesthetically unpleasing and most possibly to be an unsuitable building material.

## **6.9 Post occupancy**

The following section analyses the responses received during the post occupancy survey aimed at end users, i.e. tenants and owner occupiers. Overall 239 householders completed the questionnaire out of 26 project teams involving 442 householders. Of the 239 respondents 67% were tenants and the remainder owner occupiers (Table 3). The questionnaire was designed to gather feedback about their perception of PV systems, focusing, amongst other issues, on impact on electricity bills, environmental benefits and visual appearance. The results aim to demonstrate the end users level of satisfaction and ease of monitoring, as well as their general understanding of PV systems, how they operate and whether there were any maintenance problems. Each project team was responsible for conducting the survey for their PV cluster. Householders were asked to complete the questionnaire after a minimum of one year occupation following installation. This was considered to be sufficient time for occupiers to notice any impact on their electricity bill or for operational problems to materialise. A copy of the questionnaire is given in appendix 2.

### **6.9.1 Survey participation**

The return rate of 54% (239 out of 442) could be seen as relatively low as the DFT target was set at 75%. General consumer surveys based on cold calling, on average only achieve a 10% response rate, therefore 54% is actually quite good. It is also interesting to note that over 40% of participants did not realise that the PV installation and monitoring was part of a DTI research programme supported by 100% funding. It seems likely that even more householders might have taken part had they been aware of this. Overall the analysis had to exclude two projects or 32 expected responses as one experienced severe installation delays and the other one wanted to clarify electricity buy back contracts for householders before asking them to complete the survey.

Other reasons for this low participation might partly be due to the fact that properties have changed tenants/owners since the start of the DFT. This could therefore result in less awareness amongst these new PV DFT participants. Also according to a number of comments householders and some project team members have felt the 'novelty had worn off', thus making it more difficult to get a 100% response. This is despite some of the projects teams' best efforts, for example sending the questionnaire repeatedly, undertaking face-to-face and

phone interviews or combining its completion with a general tenants visit. As with any survey completion does depend on the householders' willingness and availability, therefore overall one can say that it is precisely because of the project teams' major effort that this response rate was realised.

	Frequency	%
Owner occupier	80	33.6
Tenant	158	66.4
Total	238	100.0

Table 3: Split of respondents into owner occupiers and tenants.

Table 4 shows that the timescales of when householders were told about the PV system loosely correlates to the type of development, whereby the majority of new-build house buyers were told at the purchase or moving in stage and existing occupiers during the concept stage. Two-thirds of the new-build properties, which were told at the concept stage, were actually part of co-housing projects. Within these project teams individuals had much more involvement in the overall property design than within other developments.

	Stage at which householders were informed about the PV system					
	At the concept stage	During purchase/moving in	Installation	More recent than previous choices	Not sure	Total
<b>Development</b>						
New-build	14%	36%	10%	3%	4%	67%
Retrofit	20%	3%	1%	1%	2%	26%
Mixed	3%	2%	0%	1%	1%	6%
Total	37%	41%	11%	4%	6%	100%
<b>Amount of time living in property (years)</b>						
Average	5.99	1.79	2.08	1.58	6.95	
Minimum	0.33	0.04	0.92	0.08	0.42	
Maximum	30.00	3.25	4.00	3.17	28	

Table 4: Overview of the different stages at which householders found out about the PV installation, broken down into length of occupancy and type of development (n=239).

When asked to specify how long the system had been installed 82.9% of respondents stated they had some idea of how long it had been there whereas 17% weren't sure. The average estimate came to just under two years, which matches the DFT timescales. It is also interesting to note that the estimates within each project team are quite close together suggesting that householders estimated correctly.

## 6.9.2 Understanding the system

Even though the majority of respondents were told about the system over a quarter answered that they had no understanding of how it actually worked (Figure 45). Of the 74% stating they had at least some understanding the main sources of knowledge were as expected, either housing associations, developers or installers. A large proportion also quoted "others" including co-housing company, workmen, warden, electrician, general knowledge and

electricity suppliers' representatives.

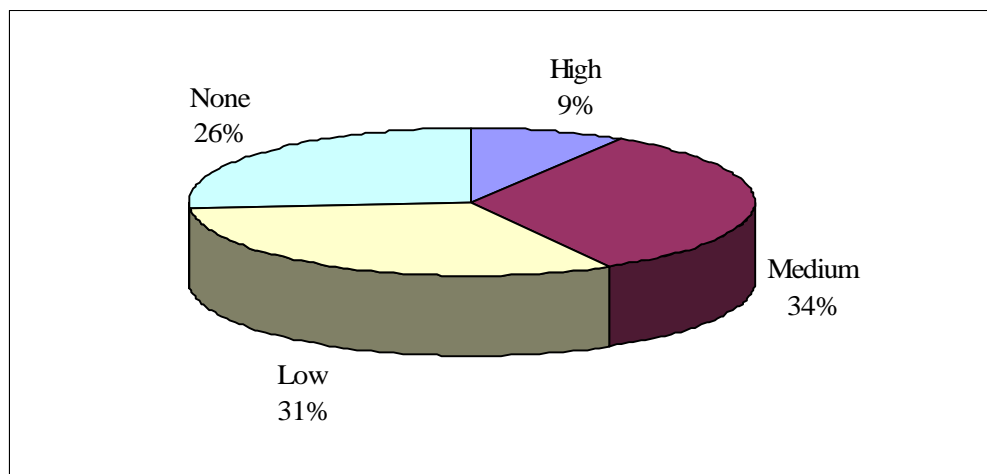


Figure 45: Level of understanding by householders (n=239)

The majority of people (65.8%) were satisfied with the explanation given. However the most common response by the ones unhappy about the information was that it was insufficient and difficult to understand. Table 5 gives extracts of the replies received indicating that there is a lot of confusion about what it actually does and any associated benefits. Overall the statements imply that householders would like to learn more and better understand how to make most of potential savings.

Asked for info in April	No structured explanation or literature
Could have been better explained about the meters	Would like to know how much we are saving
Did not understand it	Not enough info
It does not do anything for me and does not save me any money	Nothing explained on wear and tear and how long it will last etc.
Don't know what benefits it has for me	Noise of transformer is intrusive
Don't really understand	They said it would be cheap
Don't understands high electric bills	They're not much good
I have received no explanation	Too technical and hard to follow
I was just advised to forget its there and need do nothing with it	Would like to know how much we are saving
I was only given a brief description	Would like it put in writing
I would like details of capacity, limited factors and household equivalents, e.g. boiling a kettle	We do not even benefit from our solar panels because you have to use a certain supplier.
Don't even know if it is on	Like to know more

Table 5: Extracts of replies from householders unhappy about the quantity and/or quality of system information made available (n=77).

In order to establish how well occupiers know their system a number of questions were asked, such as “does your PV system produce electricity during the day or night” and “when is production highest”? Even though replies showed that there was generally good understanding about when the system is working, at least 10% and for some questions up to 20% of respondents were unsure or gave wrong answers. There is therefore clearly room for

further education.

This also applies to checking displays and figuring out how much is actually being produced. Even though most respondents (89%) seemed to know where the display unit was located, over 40% stated they never look at it (Table 6). In most cases this was due to not understanding what it means, other reasons given were bad eyesight or awkward positioning/location, i.e. too high up to see properly or too dark.

	Frequency	%
Never	100	42.6
Once a day	31	13.2
Once a week	33	14.0
Once a month	39	16.6
Other	32	13.6
Total	235	100.0

*Table 6: Frequency of checking display*

Nevertheless 135 respondents looked at it frequently ranging from daily to twice a year. This loosely correlates to answers given when asked how easy it was to read the displays with 134 respondents saying they found it easy. A number of these did point out that while it is readable they do not know what it means in terms of electricity. This is further proof that additional explanations would be helpful, possibly best within a simple easy-to-understand hand-out. It would also ensure that the information was readily available to any new occupiers. This also relates to maintenance issues discussed in section 6.9.6.

### **6.9.2.1 Behavioural changes**

Further understanding was determined by asking whether any steps had been taken in regards to saving energy since the PV system had been installed. Table 7 shows that about half had taken simple or low cost measures like turning off appliances or lights when not in use or fitting energy efficient light bulbs. Looking at the figures in more detail it becomes clear that at least half of these and some replying “no” actually used to do that prior to the PV installation.

Actual behavioural changes were however observed for at least 55 householders (24%) of which the majority stated that they had changed the times appliances were run to daytime. This seems fairly low but might partly be due to the occupancy pattern with a lot of householders working during the day and a lack of appliances with timers. Another reason might be lack of sufficient information about using appliances at times of PV production. This of course would require householders to be confident with reading the display units which has been identified as a major uncertainty.

	Responses		% -age of "Yes"
	Yes	No	
Energy efficient light bulbs	127	111	53.4
Energy efficient appliances	53	185	22.3
Switching off appliances/lights when not in use	153	85	64.3
Changed the way electricity is used, i.e. what time appliances are run?	55	174	24
Other	8	230	3.4
None	30	207	12.7

Table 7: Energy efficiency measures in place.

### 6.9.3 System costs

The following section in regards to house prices was completed by owner occupiers only. When asked whether householders paid more than average for their house due to the PV integration twelve thought they had. Of these four gave an estimate of how much ranging from less than £3,000 to more than £10,000. When asked whether they would pay more 28 out of 49 stated they would (Figure 46). Reluctance to pay more was often justified by not being confident the system would provide any financial gains. Also most of the positive responses came from what can be classed as green householders, with a higher than average environmental awareness. Most of these choose to live in low energy houses with integral environmental features such as composting facilities, grey water system and car sharing.

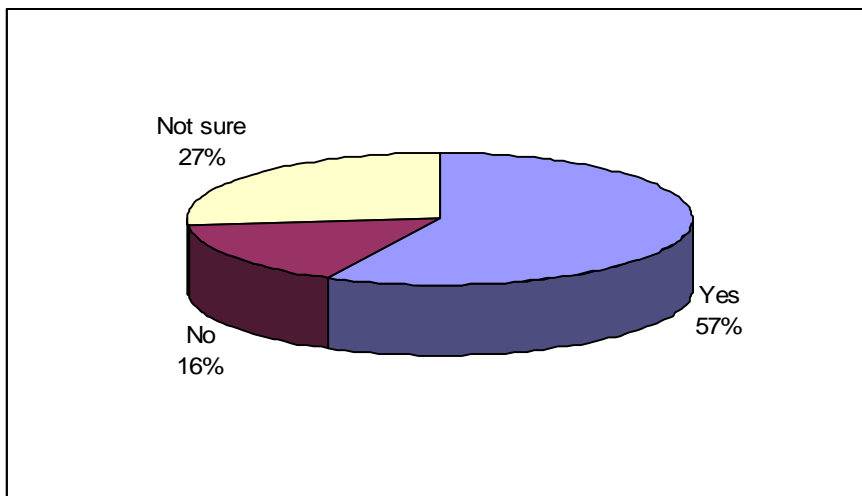


Figure 46: Willingness to pay more for a PV house (n=49).

### 6.9.4 Electricity savings

This section is looking at the perceived electricity savings and a summary of responses is given in Figure 47. Here it is interesting to note that 77 (33%) believed their electricity bill was lower but only 26 (12%) were able to actually quantify these. The majority (88%) were unsure or believed the PV contribution hadn't made any difference to their bills. Still a large number of respondents offered estimates or comments about how much it might save indicating they at least knew it was supposed to reduce bills somewhat. Estimates ranged from £21 to £200 a year whereas comments voiced uncertainty and disappointment such as "fairly reasonable", "not enough" or "my bill is up £6 a week". What becomes obvious when

looking at this long list of estimates and comments is that most relate to billing problems encountered with the electricity supplier, which was addressed as a separate issue and is discussed later.

Answers are also influenced by other issues such as the way householders pay for their electricity. For example, it will be that much more difficult for card meter users (32 out of 231) to change suppliers and get paid for exported electricity, because they do not have a contract with the electricity supplier, i.e. no bills are involved. It is however exactly these end users which would benefit most from receiving refunds.

A total of 30.5% of householders are paid by their electricity supplier for exported surplus electricity through buy-back contracts. The amounts received vary from £10 a quarter, £5 a week, to 7.2 p/kWh. Only 65 (31%) of householders received refunds, which seems quite low. It is most likely affected by the amount of respondents having had trouble with their billing, hence they were unsure of costs and/or benefits. Also a number of respondents commented that they had repeatedly tried to find an electricity supplier that would pay for exports but to no avail.

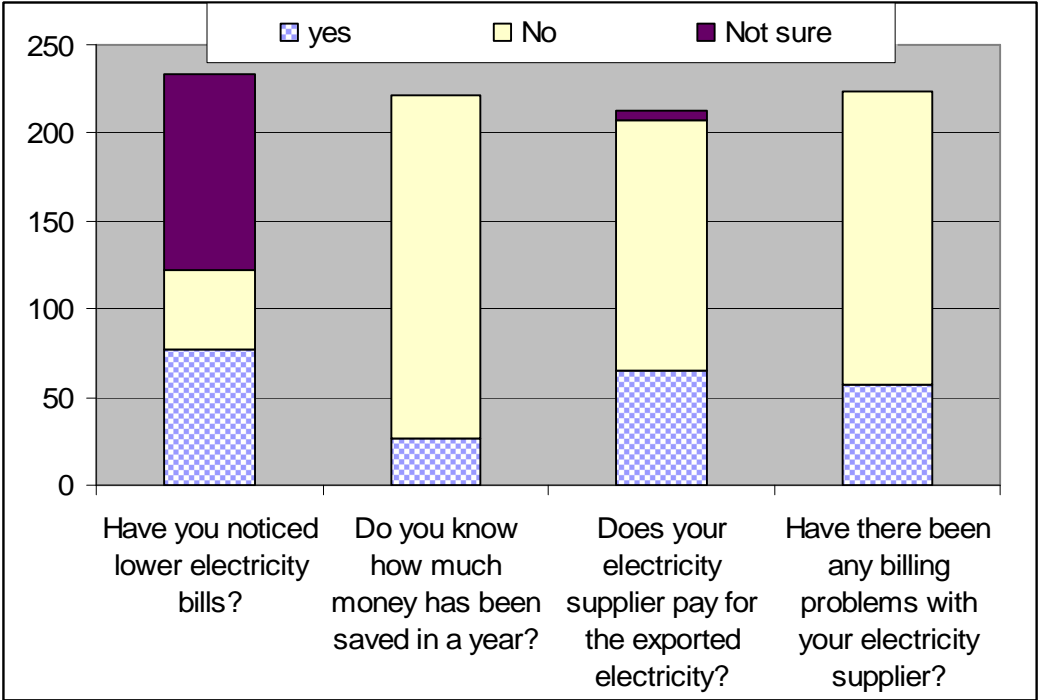


Figure 47: Electricity savings and buy-back contracts (n=239).

The question about whether there have been any billing problems caused a lot of reaction generating a long list of comments by the group (25.4%) having experienced problems. Most of these comments relate to wanting to switch electricity suppliers to ones offering a buy-back contract. There were also other problems unrelated to the PV system, however most seemed to be in relation to the meter readings. For example meter readers mistaking the import/export meter for the general consumption meter.

Some commented that they now received higher than expected bills. In one example this was to blame on a faulty meter which did not register the PV generation. As will be outlined in section 8 it is fair to say that most householders will realise some savings, however small and that the PV system can not be blamed for higher bills, which are generally a sign of increased demand or poor meter readings.

Problems encountered can be grouped into the following categories, some of which are unrelated to the PV system:

- Bill sent to wrong address
- Bill too high
- Waiting a long time to receive the first bill
- Electricity supplier unable to provide information on exporting electricity
- Current electricity supplier does not offer buy-back contract
- Difficult to find supplier offering a buy-back contract and subsequent switch
- Meter readers confusing import/export meters (used for DFT monitoring) with general consumption unit

### 6.9.5 Environmental benefits and visual impact

There seems to be some confusion about the actual environmental benefits, as nearly half (110 out of 229) stated that they were unsure about whether the system saved greenhouse gas emissions and a further nine percent claiming it did not.

The majority of householders (60%) thought the visual impact did not make any difference to the appearance of their house. With over 30% stating it actually enhanced it. About half also received positive comments from others including neighbours and friends. Most of these comments (57.7%) were made without having to probe and is therefore evidence of people taking notice and showing an interest. Most enquiries were about what the system does, how much is saved and costs.

### 6.9.6 Operation & Maintenance

Overall the systems seemed to operate with only minimum maintenance requirements, as less than 30% experienced disruptions (Table 8). Mainly in relation to meter readings, as most of the issues quoted within “other” related to meter readings. Only 6.7% of the occupiers who had experienced problems stated that they had to arrange a call out for system repairs. Two replies actually mentioned that PV panels had come loose during strong winds. This was actually pinpointed to using insufficient fastening methods and was rectified immediately on all effected installations within that site.

One needs to keep in mind that some of the systems are monitored remotely with inverters located in communal lofts. Here problems could have been picked up by for example the Housing Association and rectified without the householder realising what was going on. Also the monitoring requirements were specific to the DFT and would not affect general domestic PV installation (also see section 7).

	Responses		Percent Yes
	Yes	No	
Panels/tiles	8	230	3.4
Inverter	14	224	5.9
Meter(s)	20	218	8.4
Monitoring	12	226	5.0
Vandalism	0	239	0.0
Theft	0	239	0.0
Other	25	213	10.5

Table 8: Maintenance issues.

### 6.9.7 General level of acceptance

Respondents were asked to rate the aspects that they like about the system (Figure 48). The highest rated aspect was that the system saves them money with 74% rating it as most important, followed closely by the fact that it is good for the environment (55%). Aspects such as visual impact and talking point with family and friends were rated as much less important. The educational value for children was highlighted within other aspects.

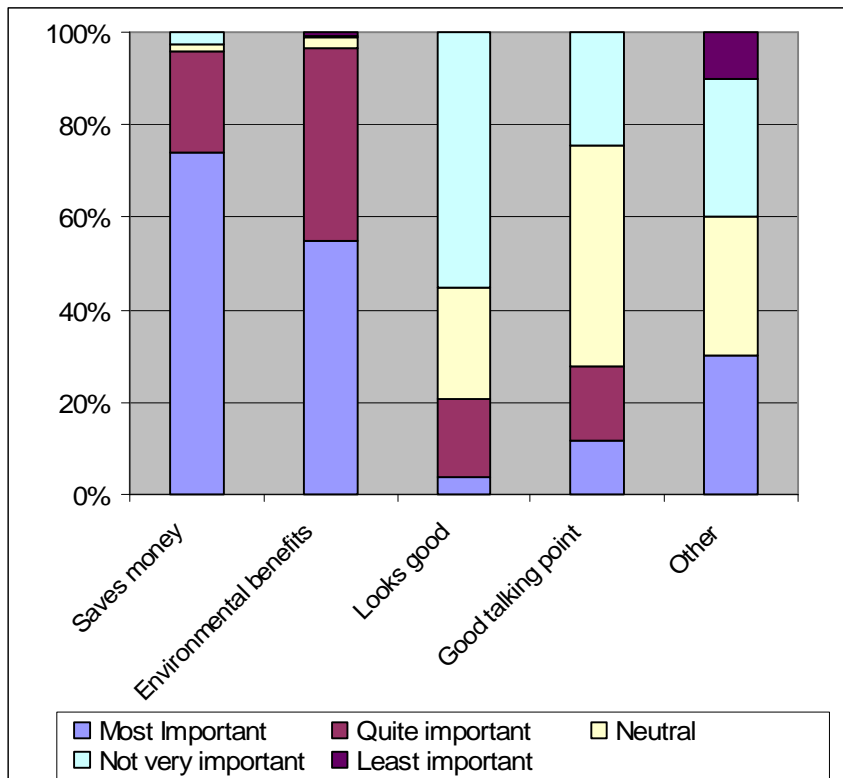


Figure 48: Reasons for installing PV (n=146/171/78/61/10).

Evaluating which aspects were least popular showed that the majority of householders were overall satisfied with the system with negative responses only ranging from 4.6 to 13% (Table 9). Disturbance was the least valued aspect, keeping mind that the DFT required significantly more access especially within retrofitting PV and monitoring systems and/or retrieving data. Although 13% cited other aspects, these related to a whole range of issues. Most of which have been identified in previous sections, such as uncertainty about realising financial pay back.

	Responses		Percent Yes
	Yes	No	
Visual impact	14	224	5.9%
Maintenance problems	11	227	4.6%
Spending tax payers money	18	220	7.6%
Disturbance	23	215	9.7%
Other	31	207	13.0%

*Table 9: PV DFT system - Unpopular aspects.*

Finally 93.5% of all the respondents answered that they think the use of solar electric systems should be more widespread. This overall acceptance of PV is also reflected in Table 10, with 194 respondents stating that they like the installation to a certain degree.

Also the majority of respondents (70%; n=239) indicated that they would recommend a PV system to a friend or relative.

	Frequency	%
<b>I like it a lot</b>	121	56.5
<b>I quite like it</b>	41	19.2
<b>It's OK</b>	32	15.0
<b>I don't like it much</b>	13	6.1
<b>I don't like it at all</b>	7	3.3
<b>Total</b>	214	100.0

*Table 10: PV DFT systems – Customer opinion.*

### 6.9.8 Summary of Post Occupancy Survey

The results presented here give a good overview of householder perception of PV although they have to be read cautiously in view of the 53% return rate. This indicates that it was probably the most interested or affected householders replying, most likely skewing the overall results towards a more positive view.

Overall there is a very high level of acceptance of PV systems but at the same time a certain lack of understanding about how they work and might impact on their (daily) routine, electricity costs and environmental credentials. Although householders affected by problems were in the minority recurring issues can be categorised into:

- Lack of understanding how the system works
- Difficulties establishing output, i.e. reading displays and/or understanding what they mean
- Uncertainty about financial pay back
- Electricity suppliers: finding and switching to a green tariff, billing
- Faulty monitoring equipment
- Faulty inverters

Most of these could be addressed by making appropriate information available, allowing householders to carry out simple visual checks and perform minimum maintenance as required. Combined with service contracts ensuring equipment is checked regularly by professionals. Issues surrounding buy-back contracts are more complex, partly due to the

limited choice of electricity suppliers, as well as variations in the level of refunds. Also having to switch electricity supplier can be a daunting task at the best of times and might mean losing other financial benefits of present, often dual, supply contracts.

## **7 Monitoring**

The monitoring carried out by the Project Teams was co-ordinated by the project Monitoring Contractor. This process consisted of the following stages:

- Development of a specification for the monitoring required, which was then included as part of each Project Team's contract,
- Before monitoring officially started, a small amount of sample data was required from each team, to ensure that the results they were producing were consistent, and in the format specified,
- A Monitoring Inspection Visit was then arranged in order to check all aspects of the equipment installed, and to assemble details of what equipment was being used,
- Data was then submitted to the Monitoring Contractor at specified intervals for detailed checking. When problems were found these were fed back to the Project Team. In some cases data was resubmitted as a result of this inspection, in other cases faults with instrumentation were rectified so that future data would not suffer from the same problems,
- Finally, when data was considered satisfactory, it was passed to the Data Analysis Contractor at the University of Northumbria.

### ***7.1 The purpose of monitoring***

The key goal of the monitoring process was to establish the performance of the installed PV systems under real operating conditions. More specifically we set out to:

- determine whether the systems are operating in line with predictions. This is most succinctly expressed in terms of the Performance Ratio, which expresses observed system output in terms of the output expected,
- to establish whether performance is consistent across installations on a given site, and also whether similar performance is observed when looking at identical systems installed on separate sites,
- to explore the reasons for any discrepancies observed between expected and observed performance,
- to determine the performance of individual system elements (generally the arrays themselves and their associated inverters), and
- to determine the fraction of the dwelling electrical load which is provided by the PV system.

### ***7.2 Outputs required from the monitoring process***

To achieve the above goals it was decided that two full year's data should be collected from each project. This data should be essentially continuous, and should be internally consistent.

### ***7.3 Quantities measured***

To satisfy the above requirements a list of the quantities which would need to be measured was generated. These were:

- solar radiation on the horizontal and in the plane of each array
- ambient temperature
- the temperature of a representative part of the array
- the DC output of the array
- the AC output from the inverter
- the total amount of electricity imported to and exported from the dwelling

To allow the analysis of short term effects such as inverter drop-out or shading problems it was decided that data should be recorded every five minutes. The quantities being measured generally fluctuate more quickly than this, and in order for the recorded values to provide a true picture of system performance quantities must be measured at more frequent intervals, and averages or totals generated for recording. The maximum measurement interval which could be tolerated for each quantity was determined, and formed part of the monitoring specification. The monitoring specification also contained specific guidance on sensors for each quantity measured.

Next, a common format for data delivery was laid out. This required that separate files were generated for each dwelling on each site. The data within each file should be arranged in lines, each of which contains the recorded data from one five minute interval, with each value separated by commas (so called commas-separated-variable or csv format). This approach had considerable advantages over other options, such as submitting the data in a spreadsheet:

- a common format across all projects means that common data checking and analysis programs can be used, greatly reducing the scope for errors,
- because the data files have no headers in them, files from a given dwelling can readily be concatenated to produce a single file covering a longer period of time,
- data can be read by a wide variety of software. In fact Excel, Matlab, Axum and Delphi were all used in the subsequent data checking and analysis, and
- the chosen format provides a ready way of indicating missing values. Individual missing data values may be denoted by an empty field, and periods for which all data has been lost may be denoted by missing records.

As part of the monitoring requirement it was specified that no more than 8% of the data for any given calendar month should be missing.

Finally, a convention for naming data files before submission was developed. Each project was allocated a unique two letter code, and data filenames were based on this code, a number which identified a dwelling within a given project, and a file sequence number. In this way, every single file submitted to the monitoring contractor had a unique name, and software could readily be written to work through the entire database of files if required.

#### ***7.4 Measurement accuracy***

Inevitably, the accuracy demanded of each measurement required is determined by compromise. In an ideal world all quantities would be measured to an accuracy which allowed the results derived from them to be sufficiently robust to allow even small changes in performance to be regarded as significant. In practice sensors have only limited accuracy, and obtaining more accurate sensors may increase costs significantly. The accuracy actually needed for a given measurement therefore has to be carefully considered. Table 11 summarises the accuracies which were originally specified.

The values shown in the table are readily available from low cost sensors. They allow array efficiency to be determined to within an accuracy of  $\pm 7\%$ , and inverter efficiency to  $\pm 4\%$ .

Quantity	Required accuracy
Solar radiation on the horizontal	± 5%
Solar radiation in plane of array	± 5%
Ambient temperature	± 0.5 °C
Array temperature	± 0.5 °C
DC Electrical output of pv array	± 2%
AC output of inverter	± 2%
Electricity imported to building	± 2%
Electricity exported from building	± 2%

Table 11: Accuracies required from monitoring system

### 7.5 Data checking

Data was returned to the monitoring contractor for checking before being passed to the data analysis team at Northumbria University. It was considered vital that Project Teams should submit data on a regular basis, in order to avoid problems not recognised by them persisting for too long. However, returning data every month over the whole monitoring period would have placed an excessive load on both the Project Teams and the Monitoring Contractor. Instead a schedule was developed in which data was returned at one-month intervals at the start of the monitoring period, when it was considered that problems were most likely to occur, and then at progressively longer intervals until, during the second year of monitoring, data was being submitted on a six monthly basis (see Table 12).

Year	1												2							3	
Month	1	2	3	4	5	6	7	8	9	10	11	12	1	2	3	4	5	6	7	X	1
Data																					

Table 12: Schedule for submission of data over the two year monitoring period

In each case a shaded cell denotes that data complete up to at least the end of the preceding month should be returned by the 10<sup>th</sup> of the month shaded. For example, if monitoring begins on 1<sup>st</sup> March, data for at least the whole of March should be returned by 10<sup>th</sup> April, data complete up to the end of April should be returned by 10<sup>th</sup> May, and so on. Once received, the data was subjected to a two part checking process. The following checks were carried out on the dataset as a whole:

- missing records were counted, and the positions of gaps tabulated,
- individual missing data points were counted,
- the total number of missing points was expressed as a percentage of total number of points that should be present, based on start and finish times of the dataset,
- total solar on array and array DC output were tabulated, and their ratio expressed as an average effective solar aperture,
- total inverter output was tabulated and average inverter efficiency derived,
- the linear correlation coefficient between horizontal and array solar was calculated and a warning issued if it was less than 0.9,
- the linear correlation coefficient between array solar and DC output was calculated and a warning issued if it was less than 0.9,

- the linear correlation coefficient between array DC output and inverter output was calculated and a warning issued if it was less than 0.9.

Next a series of checks was carried out on each individual record:

- if the record was recorded during daylight hours check solar radiation is between  $-1\text{Wh}$  for the five minute integration period (corresponding to an average insolation of  $-12\text{W}$ ) and  $115\text{Wh}$  ( $1380\text{W}$ )
- if the record was recorded during the night hours check solar radiation is between  $-1\text{Wh}$  for the five minute integration period ( $-12\text{W}$ ) and  $1\text{Wh}$  ( $12\text{W}$ )
- check that ambient temperature is in the range  $-10$  to  $35^\circ\text{C}$
- check that array temperature is in the range  $-10$  to  $55^\circ\text{C}$
- check whether the AC output of the inverter is larger than the DC output of the array (making an allowance for the allowed measurement resolutions)
- check whether exported electricity is greater than the AC output of the inverter (making an allowance for the allowed measurement resolutions)
- check whether imported electricity is greater than the capacity of the grid connection (initially assumed to be  $60\text{Amps}$ )

## **7.6 Monitoring problems**

A wide range of problems was identified in data delivered to the Monitoring Contractor. In some cases it was possible to provide feedback to the Project Team which allowed them to 'rescue' lost data. For example in one case files from one site were found to contain no values at all for exported energy. This was reported back to the Project Team who confirmed that an error had crept into the program used to translate data from their data acquisition system into the project common format. Fortunately the original files had been retained and once the translation program had been corrected it was re-run to generate a complete dataset. In another case time shifts had occurred due to missing data records for some sensors – when the files were translated the resulting shifts were readily identified from the poor correlations between system performance and climate data.

In many cases it was not possible to recover lost data, but in general, detailed inspection and prompt analysis of data allowed problems to be quickly detected. Data loss was therefore at least kept to a minimum by rapid identification of problems.

The most significant problems encountered were data interruptions, solarimeter shading problems and power measurement problems. Each is discussed in more detail in the following sections.

### **7.6.1 Data interruptions**

Inevitably in any monitoring project as large as this, some data was lost. The extent of data loss varied widely:

- in some cases data was lost for periods of only a few hours. These losses were generally within the 8% criterion set out in the monitoring specification, and no action was taken. The Sunny Boy Controller, which many teams used for data recording, did appear to periodically miss periods of data for no obvious reason, and this accounted for many of these short term losses,
- in other cases data was lost for up to a week, which was often the interval at which teams collected data from each system. In many cases these losses were due to problems with modems. The unavailability of a connection would prevent data being retrieved, the

limited data memory then filled up, and data was lost,

- in two cases Project Teams opted not to record data at all at night. In both cases the teams failed to follow the required data delivery schedule, with one team supplying data only after the two year monitoring period was complete and their oversight was not therefore detected. Whilst the missing readings are not a problem for solar, system performance or electricity export data, they do mean that ambient and array temperatures and household electricity import data are not available for those sites,
- finally, in the most severe cases data was lost for several whole months in succession. In these cases the Monitoring Contractor typically asked Project Teams to carry on data collection beyond the two year period, to make up for the losses. Depending on when data was lost this approach did not necessarily mean that the final data set contained data from all times of year, but it did at least provide the required quantity of information.

### 7.6.2 Solarimeter shading problems

As part of the data inspection process, the correlation between array output and incident solar radiation is checked. This served to identify problems on a number of sites. In one case the correlation was found to be very poor. Figure 49 below shows an example.

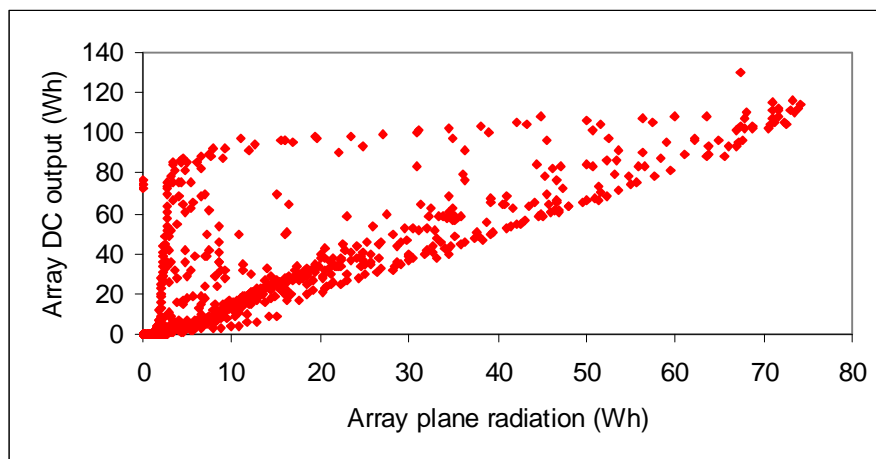


Figure 49: Example of poor correlation between array output and radiation

Closer examination of the five minute records revealed that correlation was good for part of each day, and then became very poor. The most obvious interpretation of this was that the instruments used to measure solar radiation were mounted in positions where they were severely overshadowed at certain times of day, and further inspection of the data indicated that this was most likely to be the case. The apparent array efficiency was calculated as a function of time of day. Interpreting the data in this way revealed that credible values were obtained while correlations were good, but physically unreasonable values (over 100%) were obtained when correlation was poor. This further pointed to a sensor overshadowing problem.

When the Monitoring Inspection Visit was carried out it became immediately apparent that this was the case. The solarimeters had been mounted on gable end walls approximately 200mm below the roof line, as shown on the photograph Figure 50. This resulted in them being significantly overshadowed to diffuse radiation at all times, and to direct radiation for approximately half of each day.



Figure 50: An overshadowed solarimeter

A number of possible solutions to the problem were explored. The first was to combine data from different instruments which were on similar orientations, but were overshadowed at different times of day. This approach inevitably leads to data from an incorrect orientation being used for part of the day. In one case it would have resulted in data from a sensor with a 45° orientation error being used at certain times of day. To gain an idea of how serious the resulting measurement error might be the 20 year average solar radiation figures for surfaces with a 30° tilt oriented South and South West were plotted against on a monthly basis and are given in Figure 51. It also shows the percentage discrepancy.

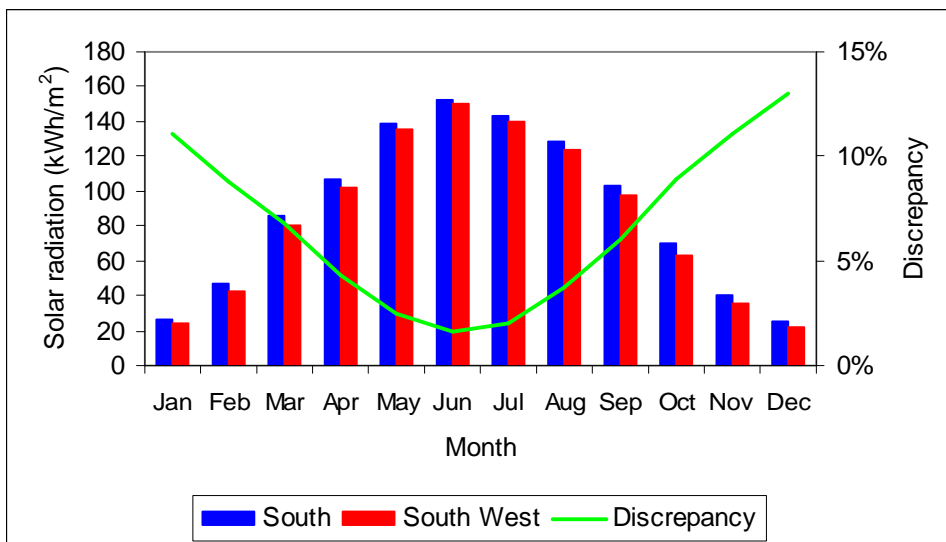


Figure 51: Errors associated with 45° misalignment of solarimeter

The figure implies that the impact of a 45° misalignment is likely to be in excess of the accuracy required for these measurements, which is  $\pm 5\%$ . It was concluded that this solution to the problem would result in the derived measurement being unacceptable at almost all times when data from a sensor on the incorrect orientation was being used. Even during

periods when the sensor was not overshadowed to direct radiation, the shading of diffuse radiation would also produce errors. It was concluded that the idea of combining measurements from different sensors at different times of day was not practical.

The second solution considered was to install a separate weather station, with sensors mounted on all the necessary orientations. This could have been monitored by an additional data logger, or connected to spare analogue inputs on existing Sunny Boy controllers. The most obvious way of rectifying the problem was to move the instruments into a position where they are no longer overshadowed. This was done by producing a simple bracket to support selected instruments above their existing mountings, and the problem was resolved.

### **7.6.3 Power measurement using the SMA inverter**

Early in the project, a number of Project Teams indicated that they were keen to use SMA Inverters to make the required measurements of their own DC power input and AC power output. Although the specified accuracy of this system did not meet the criteria in the monitoring specification, in the interests of reducing costs it was decided that this measurement scheme should be permitted. In many cases SMA Sunny Boy Controllers were used to record these power measurements, and also to record the outputs of the various other sensors.

It is now widely acknowledged that there are significant errors in the indications of DC input and AC output power provided by the SMA inverters. To address this issue, a small amount of additional funding was made available to allow a number of sites to install reference AC and DC power meters to allow the magnitude of the errors to be quantified. The goal of this exercise was to address the following questions:

- how large are the errors which are introduced by using the inverters for power measurement ?
- can the data available be used to generate a straightforward correction procedure for a particular system ?
- can the same correction process be used over a wide range of operating conditions, or are different correction algorithms necessary at different times of year ?
- can a common correction algorithm be used across different sites ?

To achieve these goals the investigation has been in two parts. The first reviewed the meters used as references to determine that they would in fact give reliable readings in this application. This review was itself in two parts. The first was a detailed examination of the design of the reference meters to determine that the components and measurement technique used were appropriate to this particular task, and the second consisted of laboratory calibration of sample meters. In the case of the AC power meter particular attention has been paid to how the meter copes with non-unity power factors, and non-sinusoidal current and/or voltage waveforms, either of which may be observed at the output of an inverter.

The second phase of the review process consisted of comparing the performance of the reference meters to a trusted meter (with a calibration traceable to National Standards) in the laboratory. Figure 52 shows the results of a sequence of one such test, and confirms that this particular meter performs well down to power levels as low as 1 or 2% of its maximum range.

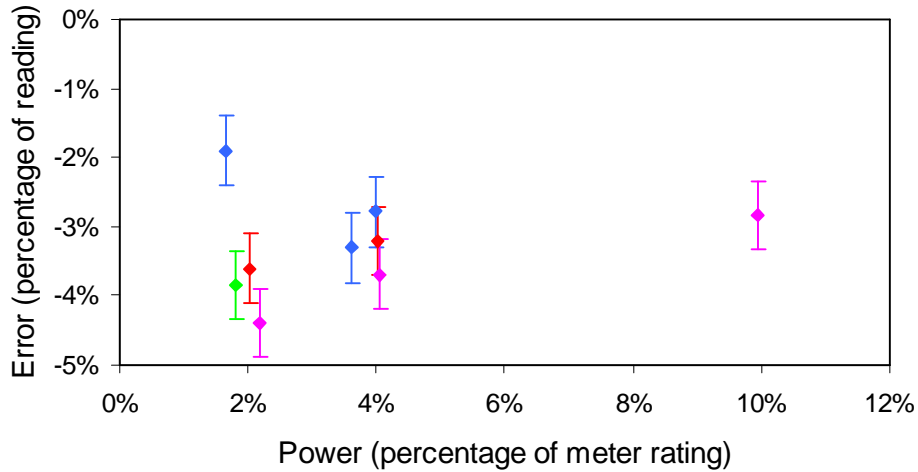


Figure 52: Sample electricity meter calibration check  
(Colours denote different combinations of voltage and current to yield a given power)

Once confidence in the performance of the reference meters had been established their measurements were compared with the power indications of the associated SMA inverters. Figure 53 shows a sample comparison between a DC reference meter and the output of the inverter.

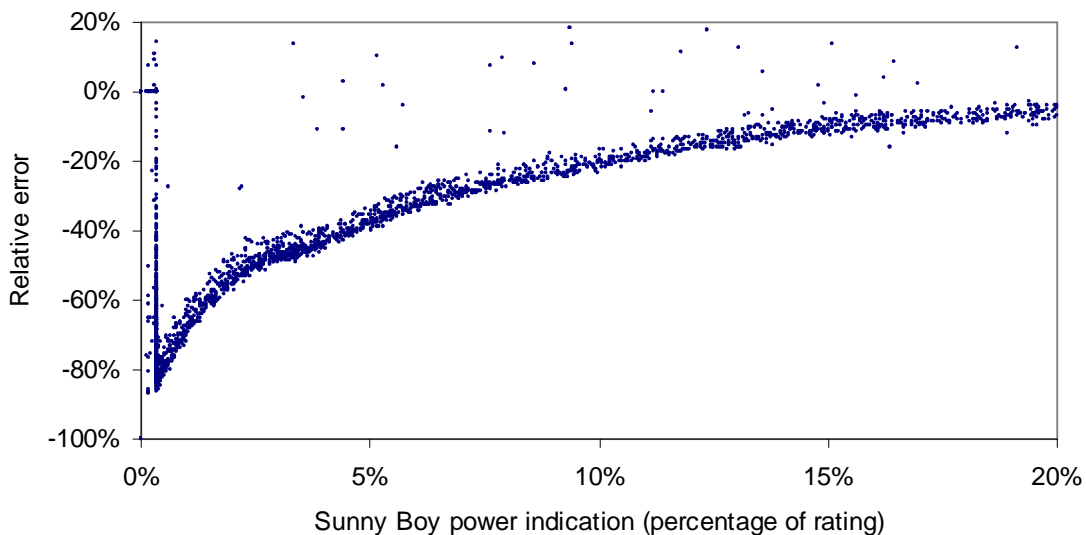


Figure 53: Errors introduced by using SMA inverter for DC power measurements

It is clear from the graph that when the DC output indicated by the SMA inverter is used in conjunction with measured solar radiation to derive array efficiency there will be significant errors when the system is operating below about 20% of its rated output. Typically, systems in the UK spend around 50% of the time operating in this region.

A similar picture was obtained when the readings of reference AC power meters were compared with the SMA Inverter indications of AC power output. Once again, the key issue is not the magnitude of the errors, but their impact on the conclusions of the project. It is clear

that without the generation of suitable corrections the output of the system cannot be reliably assessed when it is operating at powers below about 20% of rated output. However, the energy generated at these low powers represents only a small part of the total energy output: for this particular system it was only 13% during the month of April. Thus the impact of these errors on assessing system yield is relatively small. In this case they amount to only 1.6%, with the SMA inverter underestimating its own output. Armed with these comparisons, corrections were developed. Figure 54 shows sample corrections at different times of year for one site.

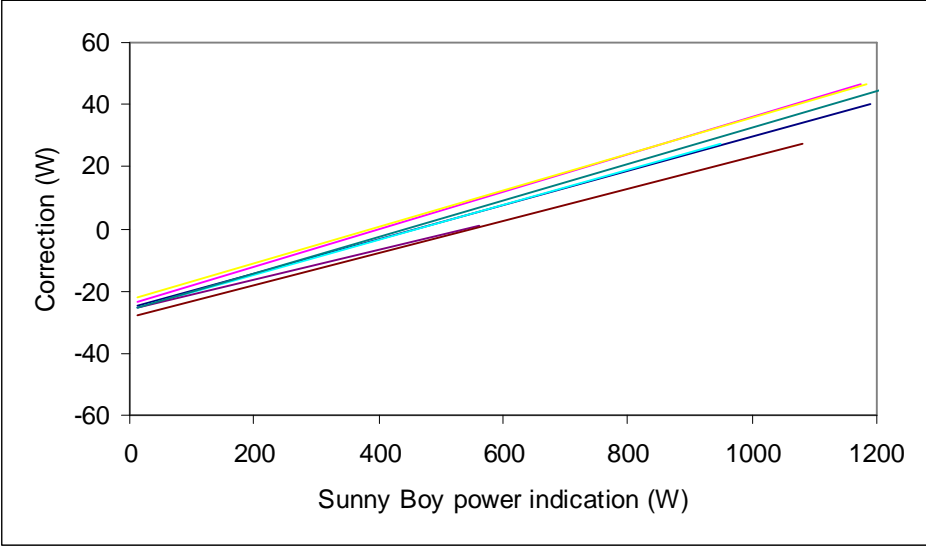


Figure 54: Sample corrections to SMA readings

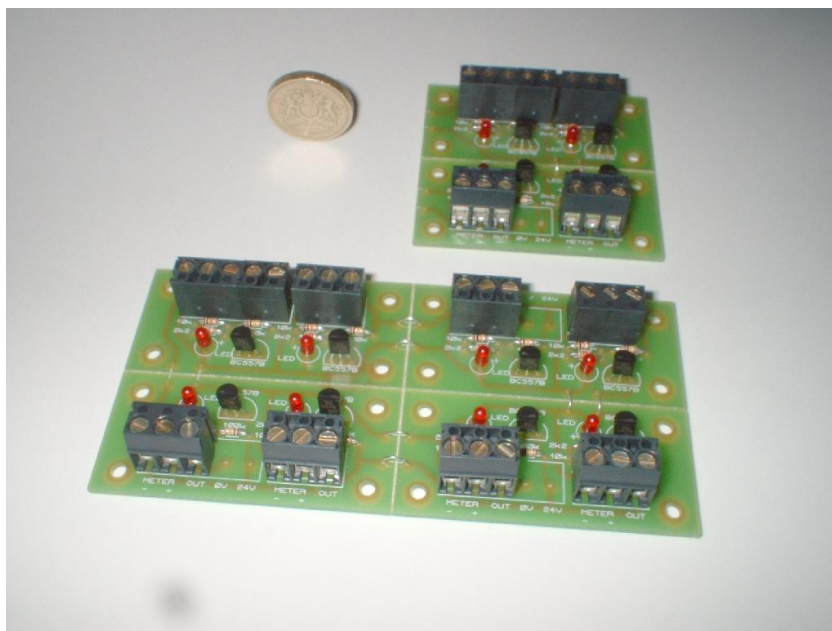
The variations in the position of the line over the course of the year are of a comparable magnitude to the scatter of the points for the single month shown. This in turn suggests that it is reasonable to use a single correction line throughout the year. The existence of a centralised Monitoring Contractor enabled these comparisons to be carried out in more detail, and across more sites, than would have been the case if individual Project Teams had been carrying out the work.

**7.6.4 Interfacing electricity meters to the Sunny Boy controller**

Many projects had used AMPY electricity meters to monitor the energy imported to and exported from dwellings in the field trials. The pulsed outputs from these have frequently been interfaced to the digital inputs of a Sunny Boy Controller Plus where they can be counted to give a direct indication of energy. On early projects there were no problems with this monitoring scheme. Later projects, however, had begun to encounter problems, finding that the Sunny Boy would no longer register the pulses from the meters. It seemed that there has been a design change to the meters and that more recent units did not have sufficient output capability to drive the Sunny Boy. Several Project Teams had been unsuccessful in obtaining any further information from the meter manufacturer.

Discussions between the Monitoring Contractor and with both AMPY and SMA, and field measurements on a Sunny Boy Controller, revealed that the problem lay in the specifications of the Sunny Boy inputs and the AMPY meter pulse output, which derived from different standards. As a result of these investigations a simple circuit was developed which amplified the output of the AMPY meter sufficiently to enable it to operate a Sunny Boy Controller digital input.

It was recognised that, although the circuit was relatively simple, building the number required on some projects would be a time consuming task for Project Teams. Accordingly a circuit board was produced which could be quickly connected between meters and Sunny Boy Controller to solve the problem. The module was made as small as practical to allow it to be fitted within the lid of existing junction boxes using self-adhesive mounting feet wherever possible. As well as containing the electronics necessary to drive the Sunny Boy Controller, the board has an indicator LED for each power meter connected to it, allowing rapid diagnosis of any problems when it is installed. In its normal form the board contains eight circuits, enough to condition all the digital inputs to a Sunny Boy Controller. However, to cater for projects where not all eight of these inputs are used the board can be subdivided to produce units which process inputs from four or even just two meters. Figure 55 shows an eight way board (in the foreground) and a four way version. The pound coin gives an idea of size.



*Figure 55: AMPY meter conditioning boards*

A 'Monitoring Information Note' was produced summarising the solution to the AMPY meter problem, and was issued to all monitoring teams. Once again, the presence of a central monitoring contractor allowed this problem to be resolved, and the solution to be quickly shared with all of the Project Teams.

## **7.7 Summary**

Data has been collected from all the sites involved in the Domestic Field Trials which will allow performance comparisons to be made between dwellings on a given site, and across sites (section 8).

The presence of a central Monitoring Contractor allowed a common data format to be established across all projects before data collection began. Requirements for measurement accuracy and frequency were also established at an early stage. Incoming data has been extensively checked, and many problems have been resolved.

The existence of a central point for collating and distributing information has also proved valuable when resolving problems which affected several sites, providing an additional

resource to Project Teams and ensuring that solutions were quickly shared across the whole project. The two most significant problems which have been tackled in this way were the analysis of the errors resulting from the use of SMA inverters for power measurement, and problems interfacing a particular electricity meter to the Sunny Boy Controller. In both cases solutions were developed and distributed to the parties needing them.

## 8 Data analysis

### 8.1 Introduction

The collection and analysis of performance data from the DFT projects allows us to address several questions useful for the development of photovoltaic systems on domestic properties in the UK. These can essentially be divided into three categories:

- What is the typical performance of UK domestic PV systems installed in the UK in the period 2000-2005 and what are the influences of system design and location?
- Where significant losses are observed, over and above those that would be expected in normal operation, what are the causes and how can systems be designed to eliminate or minimise these?
- How much can the PV system contribute to meeting the electrical demands of the house on which it is installed?

This section will use aggregated results from the DFT projects to address these questions, making use of specific examples to illustrate some aspects. In accordance with normal practice for DTI funded studies, data will not be attributed directly to a site. It is only possible to summarise the results of the analysis here and more detailed discussions will be provided in a series of publications arising from the DFT work.

This project has provided the largest data set in regard to PV system performance in the UK to date. This allows a much more robust assessment than has previously been possible. One distinctive feature of the DFT is that several systems, of the same or similar design, are installed on each site. This provides an enhanced opportunity for identification of operational features, particularly loss mechanisms, since both the weather variations between sites and the effects of different system components are removed from consideration.

### 8.2 Data Availability and Analysis

The analysis presented here includes data from 17 DFT sites and a total of 274 individual PV systems. Of these, 12 sites have two years of data available, whilst only the first year of data is available for the remaining 5 sites. Some DFT sites have experienced delays in installation and/or commencement of monitoring and the data sets are therefore not over a sufficiently long period to allow inclusion in this analysis (at least one year is required). In some cases, problems with the data collection make some or all of the data unreliable and these data sets have also been excluded from the analysis. One of the most important issues in deciding on the usefulness of a data set is the monitoring fraction, that is the number of data points measured in relation to the maximum possible. When there is only a small loss of data, then the data can be corrected making the assumption that the solar irradiation and system behaviour are the same in the unmonitored period as they are in the monitored period (usually on a monthly basis). However, data sets with monitoring fractions below 0.85, on an annual basis, were not used.

All collected data sets were analysed to provide monthly values of the main system performance parameters, weather data and information on electricity usage.

### **8.3 Typical Performance Levels for UK Domestic PV Systems**

This section will consider the typical performance levels observed for the DFT systems, together with the spread of performance and the influence of factors such as choice of components, array position and system location. The performance of a PV system is conventionally expressed by the following three parameters, each providing different information:

- System efficiency – expressed as a percentage and representing the ratio of the AC electrical output to the incident sunlight over a defined period.
- System yield – the amount of electrical energy produced in a given period (usually one year) as a function of the system size, expressed in kWh/kWp.
- Performance ratio – expressed as either a percentage or a fraction, representing the ratio of the AC electrical output of the system to that of an ideal system of the same design in the same location

Perhaps surprisingly for the non-expert, the system efficiency is generally the least useful of these parameters when we want to compare different systems, as in this case. The efficiency value is directly dependent on the choice of system components and thus can vary significantly between different system designs even if the system losses are low. Clearly, the efficiency is an important criterion at the design stage since it dictates the area required for a given power level and it is important to obtain a system efficiency in practice as close as possible to the efficiency of the module chosen (i.e. low losses). However, in regard to performance analysis, it is not as useful a parameter as the annual yield and the performance ratio.

System efficiencies for the DFT sites analysed range from around 4.5% (thin film silicon tiles) to around 10.5% (single crystal silicon modules) for systems without major loss mechanisms. The variation of efficiency will not be considered further in this report.

#### **8.3.1 Annual Yield**

The annual yield of a system is the electrical output of the system in one year as a function of the system size, represented by the nominal capacity of the array. It is usually expressed in kWh/kWp. Clearly, since the output is dependent on the amount of sunlight falling on the array, the annual yield will vary according to the weather conditions in that year and the orientation of the array surface.

At the design stage, it is usual to make a prediction of system output using one of the available software programs for simulation of PV systems. The most common package used in the DFT is PVSyst, which is available at relatively low cost. We will look later at how well the design prediction of system output has matched the reality as measured on site, but, as a benchmark, it is worth considering here the output predicted for a typical system design in a typical location. Let us consider a 1 kWp system, comprising an array of single crystal silicon modules and a single inverter of capacity 850 Wp, mounted on a south-facing roof at a tilt angle of 35 degrees. The system is considered to be located in Birmingham and average solar data for that location has been used for the simulation. PVSyst predicts an annual output of 798 kWh/kWp, based on an average in-plane irradiation level of 2.8 kWh/m<sup>2</sup> per day. The system is assumed to have no losses as a result of array shading or component malfunction. This yield value can be compared with those found in practice and discussed below.

Figure 56 shows the annual yield values obtained for all 17 sites. Where the systems have completed two years of monitoring, values for both years have been included. This is more useful than taking an average, since operational problems that reduce the yield can be more

easily identified. In a few cases, the monthly totals have been corrected for reduced monitoring fraction. It can be seen that there is quite a wide spread of values, with the category of 701-800 kWh/kWp having the highest number of occurrences.

It should be noted that the yield values are not all for the same annual period, so cannot be directly compared but the combination of all the values gives a good indication of the outputs achieved. Also, the values represent a range of tilt and azimuth angles for the array and so one would expect to see a range of yields consistent with the different orientations of the arrays. Taking an average of all the recorded in-plane irradiation values gives an average daily irradiation of 2.7 kWh/m<sup>2</sup>, that is slightly below the value assumed in the benchmark calculation. If we assume a pro-rata reduction in yield, this gives an expectation of 770 kWh/kWp for the 1 kWp model system.

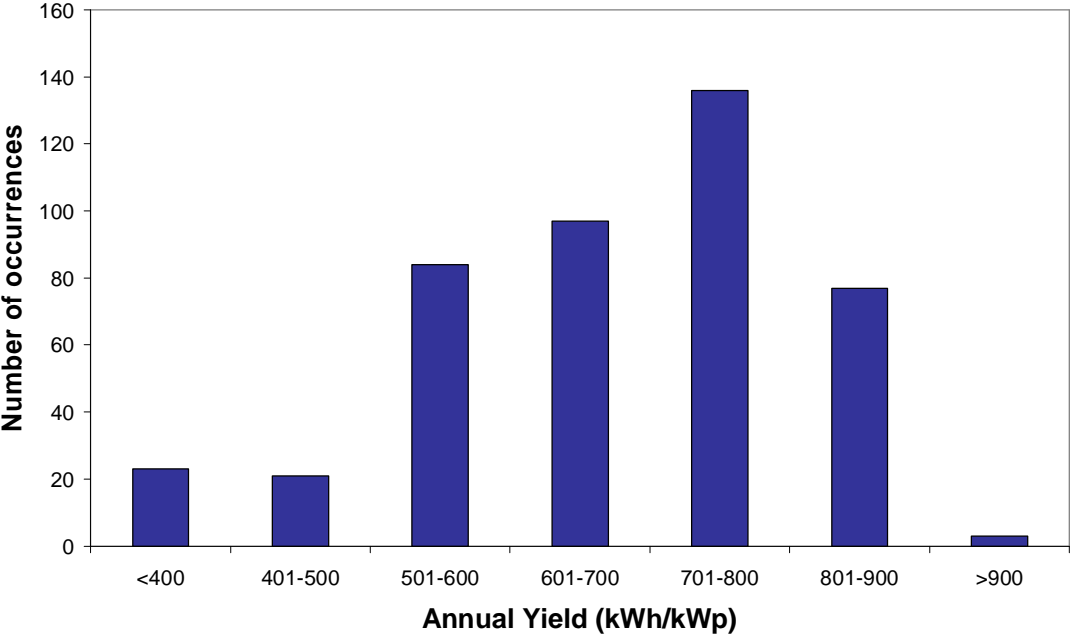


Figure 56: Measured annual yield values for PV systems at 17 sites and representing a total of 441 values. The average system size is 1.58 kWp and the average daily in-plane irradiation is 2.7 kWh/m<sup>2</sup>.

All systems with annual yields below 600 kWh/kWp have clearly identifiable losses, such as long term inverter outages or high levels of shading, when the monthly data are inspected. Those systems with yields below 750 kWh/kWp usually exhibit occasional losses due to shading, short-term inverter outages or inverter thresholds. In some cases, poor weather conditions have also reduced the yield. The system losses are discussed in more detail later in this section.

In order to determine whether location has a significant effect on output, the sites have been divided into three categories based on latitude. Four sites fall into the first category below 52°N, six sites into the second category of 52 – 54°N and seven sites into the third category of higher than 54°N. Figure 57 shows the percentage of yield values in the different yield categories as a function of location. It can be seen that the common assumption that yield values will be highest for the southernmost sites cannot be justified from the data. Inspection of the variation of values between sites shows that this only happens reliably for the southernmost site, which is located in the south west of England and gives the only annual yield values over 900 kWh/kWp. However, it is clear that many of the yield values are dominated by the loss mechanisms experienced and thus any location dependence is too small to register in this case.

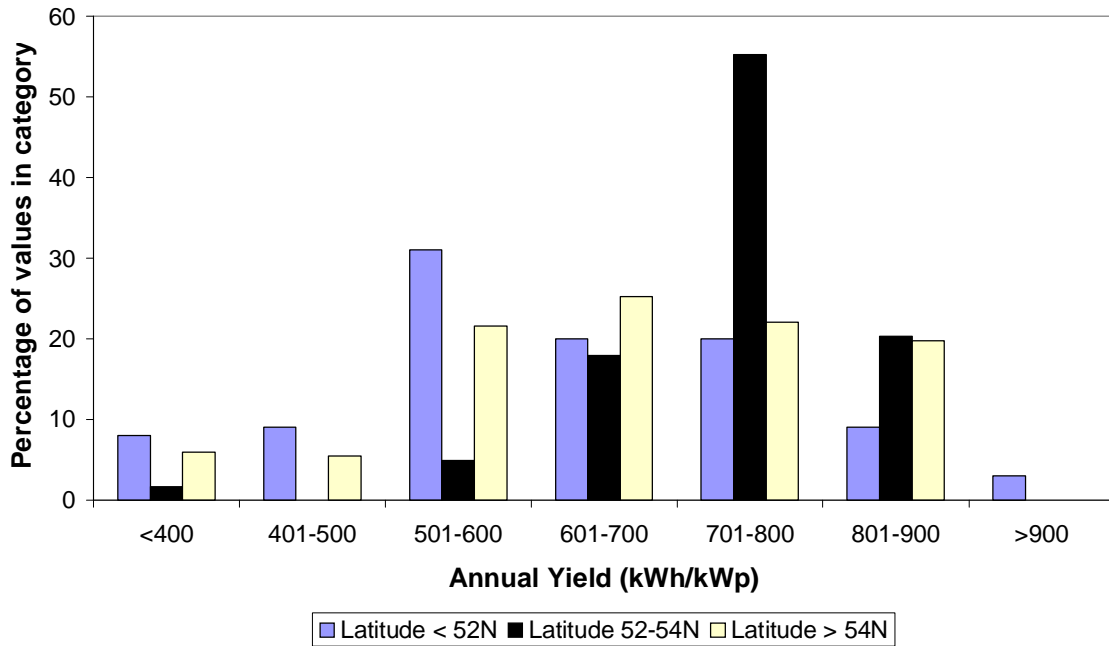


Figure 57: Annual yield values as a function of site location. The data are represented as a percentage of the total for each site to allow comparison, since the number of systems differs for each location category.

It is also interesting to consider the variation of yield with system technology and this is represented in Figure 58. Here the data are represented in three categories relating to the PV array composition. Most of the sites use crystalline silicon modules mounted in an array that stands off the roof. In our sample, 13 of the sites use crystalline silicon modules. Three of the sites use crystalline silicon cells, but in this case integrated into roof tiles and forming part of the roof of the property. The remaining site uses amorphous silicon shingles.

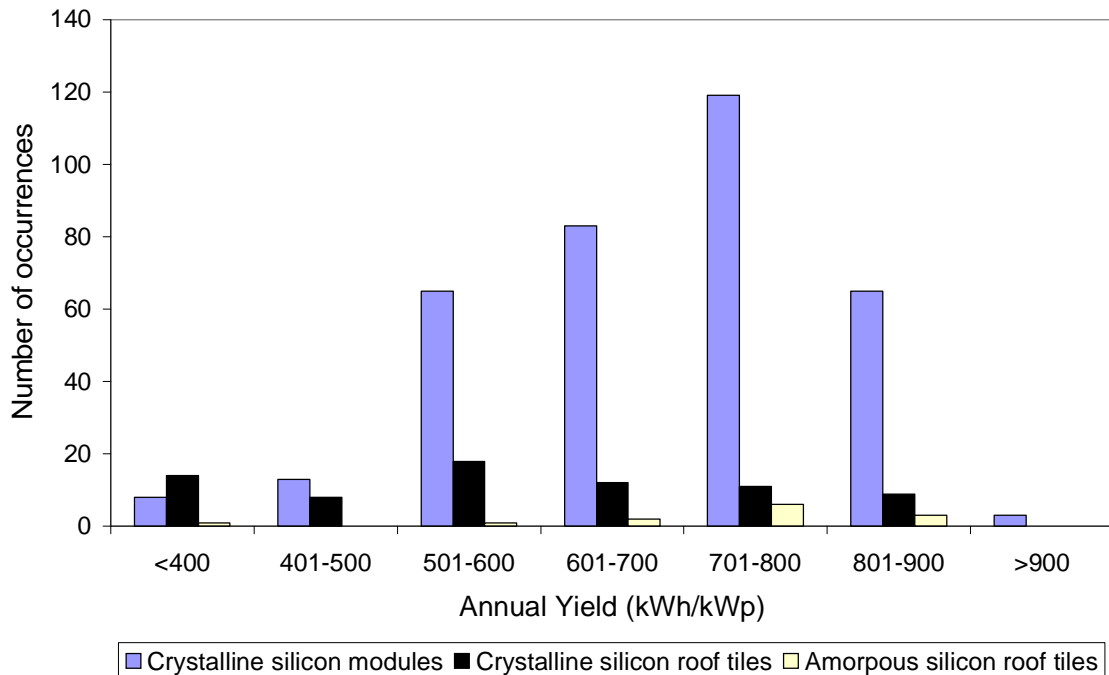


Figure 58: Variation of annual yield by PV technology. 81% of the systems use crystalline silicon modules.

In this case, the results have been presented as the number of occurrences rather than as a percentage since the disparity in system numbers provides a misleading conclusion if presented as in Figure 57. The amorphous silicon tile system shows a good yield for most systems, but the use of only a single site does not allow us to draw general conclusions from this data, especially when so many of the yield values are influenced by loss mechanisms not directly attributable to the PV array.

The three sites using roof tiles do show a tendency towards a lower yield than for the standard power modules, but it can be seen that good annual yields can still be obtained if other losses are minimised. Part of the reduction is due to the higher operating temperature for the integrated roof tile system. However, the data also suggest that, for one type of roof tiles, the power rating given in the specification sheet may be higher than that achieved in practice. Since the power rating forms the denominator for the calculation of annual yield, this leads to apparently reduced yield values.

#### **8.3.1.1 Comparison with predicted yields:**

The sites provided predicted outputs in their design reports, these being based on average solar data for the location concerned. Most project teams used either PVSYST, RETScreen or the proprietary prediction software of the installation company to predict the output, but a few did not provide information on the daily irradiation levels assumed. Most predictions of annual yield fell in the range of 740 – 840 kWh/kWp. Within the predictions, a clear geographical trend can be observed with the more northerly sites having substantially lower predicted yields due to lower assumed irradiation levels. However, in practice, the reductions were not as apparent and measured in-plane irradiation levels have not been significantly lower. Five sites showed average daily in-plane irradiation values that were significantly higher (up to 15%) than the assumed values and, where these systems did not have identified performance losses, a consequent increase in annual yield was observed.

Clearly, it would be possible to consider the match for each site, but there is only space for summary information in this report. Five sites gave measured values that were close to the predicted value, once the difference between measured and assumed irradiation levels had been taken into account. Six sites had no in-plane irradiation values for the predicted and/or measured values and so the comparison could not be completed. Two sites gave slightly higher measured values than those predicted. The remaining four sites gave somewhat lower yields than predicted but this could be attributed to inverter or shading losses in most instances.

#### **8.3.2 Performance Ratio (PR)**

The performance ratio gives a direct measure of the losses in the system since it compares the output from the real system with that of an ideal (loss-less) system at the same location and with the same irradiation levels. Values of 0.8-0.85 represent a very good system, with the 15% loss assigned mainly to the conversion of DC to AC electricity, the losses in cabling, mismatch between the modules and temperature effects. The calculation of PR involves knowledge of the AC output of the system, the in-plane irradiation and the power rating of the system. Since it is technology, system size and location independent, it is often used for comparisons between systems.

Figure 59 shows the variation of measured PR values for 13 sites and a total of 345 system years. The other 4 sites had problems with their in-plane irradiation measurements that made the PR values unreliable.

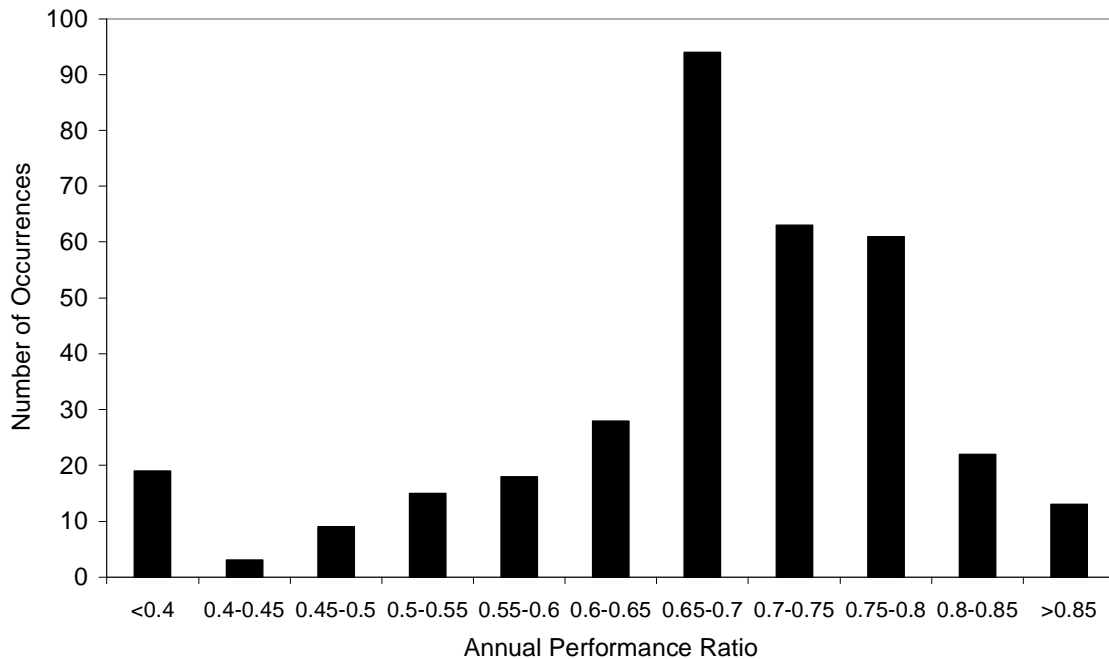


Figure 59: Variation of PR values across 13 DFT sites

This analysis indicated that 10% of the values are 0.8 or over and a further 18% are between 0.75 and 0.8. With present system design, it is unusual to be able to obtain a PR value of over 0.85 and, since most of these values occur for the same site, we believe this is mainly due to a slight offset in the irradiation measurement that results in a slightly overestimated PR value. However, these systems are still performing very well.

All the systems with PR values below 0.6 have readily identifiable loss mechanisms as discussed later in this section. The category with the highest number of occurrences is that of 0.65-0.7, whereas the aim would be to have all systems in the 0.75-0.8 category or above. If we consider a PV system with a lifetime of 25 years, reducing the PR value from 0.75 to 0.65 is equivalent to losing over 3 years of output.

Inspection of the data shows that the losses incurred here mainly result from partial shading (often from another part of the building) and/or short-term outages of the inverter. The former can be reduced with careful choice of where the array is sited, but may not be able to be eliminated entirely. It is important that the user understands the requirement to minimise shading during the system lifetime by keeping vegetation trimmed back and by placing any additions to the outside of the building (e.g. satellite dishes, cabling etc.) in such a position as to avoid shading the modules.

It is not possible to prevent occasional outages of the inverter where these are caused by grid fluctuations, but measures can be taken to ensure that the period of outage is kept to a minimum. The first task is to have some means of identifying the outage by having a readily accessible and understandable display system. The second task is the restarting of the inverter, requiring instructions for the user for simple restarts and contact details for professional assistance where this fails to clear the problem.

## **8.4 System Losses**

The previous discussions of annual yield and performance ratio have shown that many of the DFT systems are performing well with outputs in the expected ranges. However, there are also some systems with substantial losses and this section will discuss the loss mechanisms observed and suggest ways in which these can be addressed in the future.

### **8.4.1 Inverter Outages**

Lengthy cumulative periods when the inverter is not operational are the cause of the most severe system losses, although there are a number of reasons why this may occur. Of the 274 systems considered in this analysis, 22 (8%) had periods of several months when the inverter was not active. These account for over half the annual yield values below 500 kWh/kWp. Whilst a few of these systems exhibited continuing problems in both years of monitoring, most of them only had one extended period of inverter outage (although this sometimes affected both years of data).

It is not generally possible to determine the cause of the outage from the monitoring data itself, but common causes are:

- A fault in the inverter, either inherent or caused during operation (e.g. by a spike in the electrical supply from the grid) – this condition remains until the inverter is repaired or replaced
- An inverter trip, often caused by a voltage spike from the grid, which requires a manual restart of the inverter – this is usually simple to remedy provided that the user is aware that the inverter has tripped.
- Deliberate shutdown of the inverter (e.g. to allow work on the electrical system in the house) and failure to restart – again this is readily addressed if the user is aware of the problem.
- Consistently high grid voltages that prevent inverter operation since they are above the maximum voltage of the protection settings – this should not occur in theory, but problems with high grid voltage have been more frequent than expected in the DFT.

Clearly it is necessary to minimise the length of time for which the inverter is not operational. The first requirement is to ensure that the user is aware that the inverter is off. The delay between the problem occurring and the first identification appears to be quite long, even in the DFT where systems are monitored by the project team. For systems outside the DFT, where no monitoring is included, users should be provided with instructions advising them to make a regular check of inverter output and with the means for them to carry this out. This may be in the form of a usable display system and/or require issues of accessibility of the inverter to be considered. Since the inverter is normally placed in the loft space, it cannot generally be expected that the occupant will observe fault warnings on the inverter itself within a short time of the fault occurring.

The second requirement is that the user is aware of what to do in the case of the inverter failing to operate. This should consist of simple instructions regarding the manual restart and contact details to obtain professional assistance if this does not clear the problem. Ultimately, when sufficient systems are installed, companies may consider the establishment of a helpline for enquiries, although it is clear that the economic implications need to be considered.

Non-operation of the inverter due to high grid voltage is not related to a technical fault in the inverter, although in some cases it can be addressed by modification of the internal protection settings. However, in other cases, it will require modification of the grid voltage by the electricity distribution company responsible and this usually requires action on behalf of the

system installer to assist the user in demonstrating the problem and obtaining assistance from the electricity company.

### 8.4.2 Inverter Dropouts

Significant losses can also be incurred when the inverter is operating throughout, but “drops out” (i.e. the output drops to zero) at regular intervals. The most common cause of this problem is intermittent high grid voltages, such that the voltage is outside the allowed operating window of the inverter. Drop out can also be caused by problems with locating the maximum power point of the array in changeable conditions, but this is much less common.

Dropout due to grid voltage fluctuation is illustrated in Figure 60, for two systems (designated A and B) on the same site on a clear sunny day. The irradiation level was quite stable but System B experiences a large number of outages throughout the day. This clearly indicates that the problem is not related to maximum power point tracking since there are no rapid changes in sunlight level to initiate an inverter shutdown.

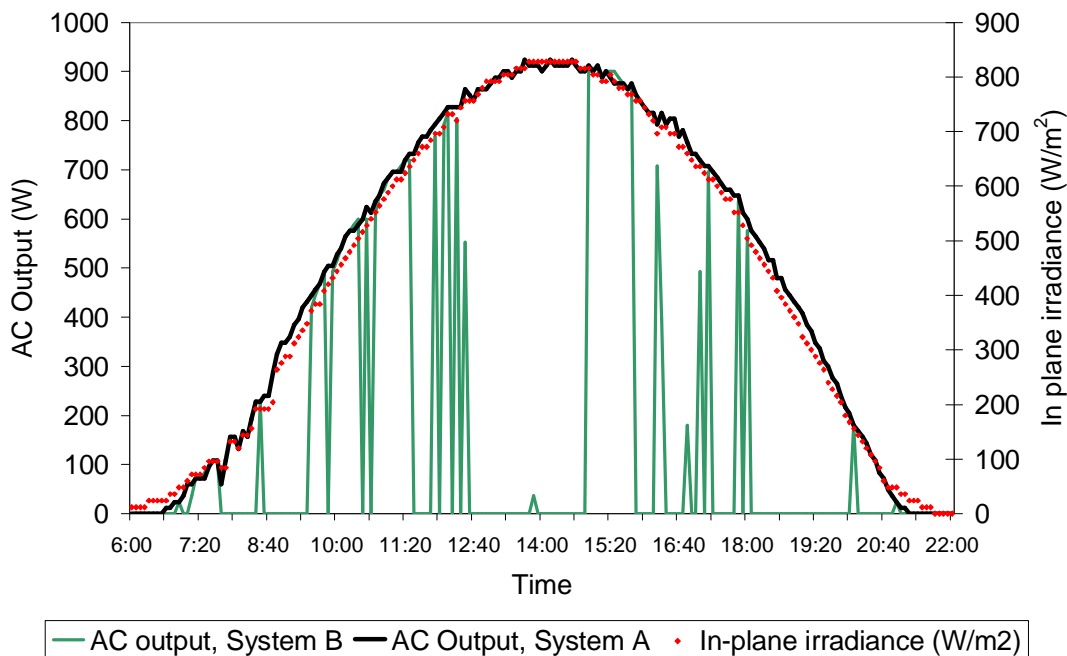


Figure 60: Illustration of inverter dropout for two PV systems on the same DFT site on a summer day.

The seasonal aspects of the variation in this case are also consistent with high grid voltage as the cause. In the summer, there is often a reduced load on the system and this can lead to a higher voltage along the feeder line. In addition, the generation from the group of PV systems connected at this site reinforces the grid voltage. Thus systems that are close to the supply transformer for the local grid line can sit at a voltage close to their cut-off limit. This can then cause outages of the inverter as voltage variations occur and, since the voltage is affected by load fluctuations, it is characterised by occurring when there is no obvious change in weather conditions. Normal operation of the inverter is recommenced when the grid voltage returns to permitted values.

This problem is not a result of faulty system design, but rather of incompatibility between the inverter operating range and the grid supply voltage. It may not become apparent until well into the operating period of the system and is often not detected at installation despite the completion of all normal checks. It is also rather difficult for the user to observe this

behaviour unless there are substantial periods of outage. However, it can lead to significant losses in power output. For the example provided, about 40% of the output of System B was lost in August compared to the output from System A and this loss occurs, of course, during the months with the highest expected output levels.

It is difficult to find a simple solution to this problem, since it is hard to predict where high grid voltages will be experienced. Four sites within the DFT have experienced intermittent or continuing problems with grid voltage and not all of these were in rural areas where the risk is considered to be highest. In due course, it is possible that inverter design will be modified for the UK market and will be more tolerant of the higher voltages experienced in this country compared to mainland Europe. In the interim, it will be necessary for installation companies to be more aware of the problem and possibly to obtain voltage measurements where there are reasonable grounds for suspecting disruption to PV operation.

It is also important that the measures implemented to allow users to identify system outages (as discussed in the section above) be able to identify the intermittent dropouts as well. This may be done from cumulative totals if expected values are also known, although there are a number of loss mechanisms that would then need to be considered in order to find the cause of low output values. Displays that allow instantaneous values of system output as well as cumulative values can be used for identification or diagnosis if inverter dropout is suspected. There are several ongoing studies within Europe addressing the issues of general monitoring and maintenance of building integrated PV systems. These should provide advice in due course.

### **8.4.3 Maximum Power Point Tracking:**

In order to obtain the maximum output from a system, the operation of tracking the maximum power point of the array must be carried out efficiently. Most inverters have a built-in maximum power point tracker (MPPT) although different algorithms can be used for the tracking process. Depending on the inverter design, there will be a defined voltage range over which the MPPT operates so as to minimise the time involved in locating the maximum power point. The installation of multiple PV systems of similar design on the same site in the DFT has allowed the identification of a loss mechanism that is believed to be directly related to this MPPT voltage window.

Figure 61 shows the output from two systems on the same site for a variable day in winter, in which the irradiance level is rather low. It is clear that both systems are operating and the outputs are varying in accordance with the variation of in-plane irradiance. However, the system designated here as D shows a substantially lower output than that for System C. The most common loss mechanisms of shading, inverter outage or inverter dropout are not responsible since, in all cases, the output curve would have failed to follow the irradiance level closely.

Although it cannot be directly tested without additional measurements on site, the cause of the reduced output is believed to be that the actual maximum power point of System D is located at a voltage below the MPPT voltage window of the inverter. Some inverter designs, including those used on this site, modify the MPPT voltage range according to the grid voltage in order to maintain efficiency. A combination of a high grid voltage on this site, although not sufficiently high to cause problems with inverter dropout, and low irradiance levels means that the array on System D cannot be operated at its maximum power point. As a result, it remains at the lowest voltage allowed by the tracking window and the output is significantly reduced. This does not happen for System C since it has a larger array (by 20%) and hence a larger number of modules in its series string. This results in a higher voltage at

the maximum power point and hence the system can operate in MPPT mode throughout. The consistency of behaviour between all the systems on this site and the observation of these losses only under low irradiance conditions supports this explanation.

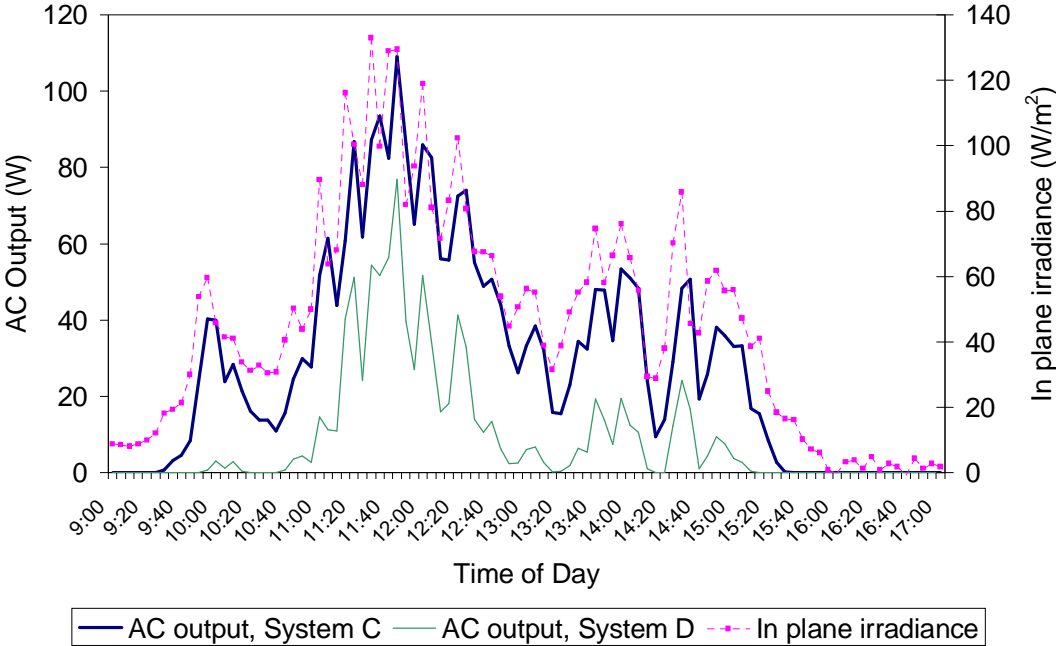


Figure 61: The variation of AC output and in-plane irradiance with time for two similar systems on the same DFT site. The graph is for a winter’s day with low irradiance conditions. System C is 20% larger in capacity than System D.

This problem can be addressed at the design stage. In most cases, system designers will use design software to investigate the matching between the array and the inverter. It is likely that most of these design programs would not have identified the potential loss mechanism for System D, because they do not assume the combination of high grid voltage, affecting the MPPT voltage range, and low irradiance levels, reducing the MPP voltage of the array. This is a situation that will only occur where the grid voltage is higher than the average in mainland Europe, such as in the UK.

It is recommended that system designers check whether their choice of inverter operates the principle of modifying the MPPT voltage window with changes in grid voltage. If so, they should ensure that the string voltage at low irradiance levels is well within the MPPT range at its highest setting.

**8.4.4 Inverter Threshold:**

All inverters have some parasitic losses and these can dominate at low load levels, so a power threshold is set below which the inverter closes down. However, if this threshold is set too high, it can lead to unnecessary losses particularly in the winter months. Figure 62 shows an example of the effect of the inverter threshold. It can be seen that, at both the beginning and end of the day, the inverter does not operate for a period of around 2 hours, even though the irradiance sensor is recording values. Indeed, in this case, the inverter does not start up until the irradiance exceeds 130 W/m² and closes down at around 200 W/m² (around 20% of full sunlight conditions). Clearly, on days with rather poor sunlight conditions, this can lead to long periods of non-operation. However, even on sunny days, output is lost at the beginning and end of the day.

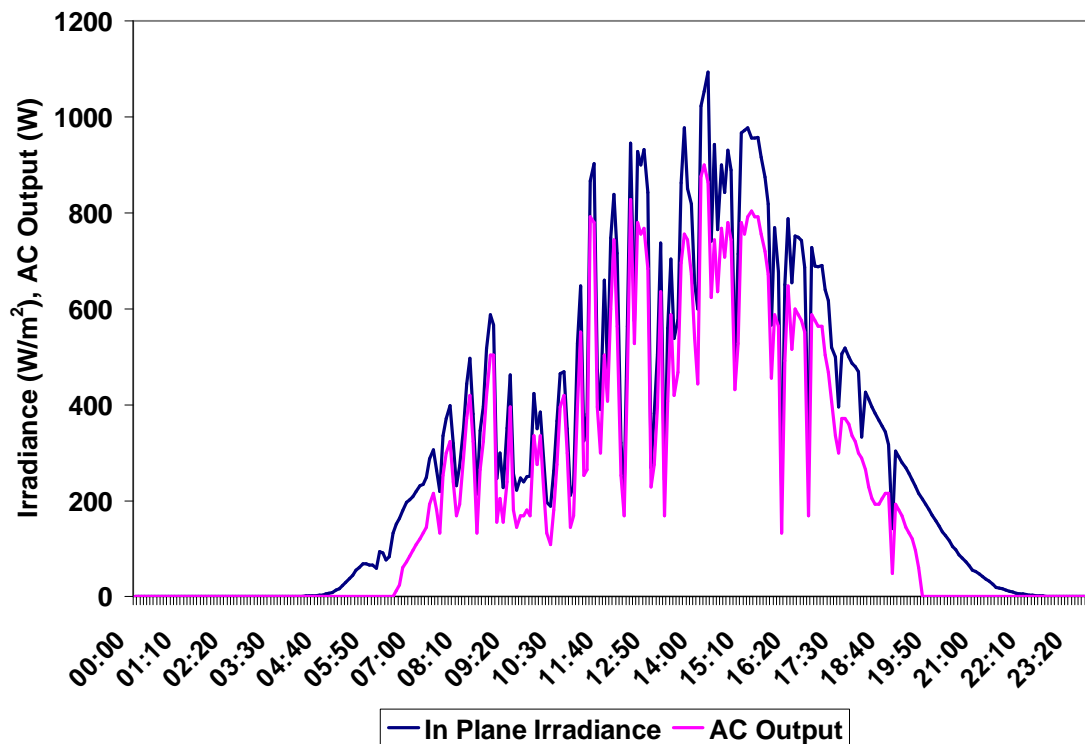


Figure 62: Example of the effect of inverter threshold on the AC output at the beginning and end of the day.

Whilst this loss mechanism rarely leads to substantial reductions in yield, it has been identified as occurring in several of the systems with yield values in 600-700 kWh/kWp range as a contributory loss to the reduction from the expected levels of around 800 kWh/kWp. It is often seen where the inverter is large for the size of the array (recommended inverter size is 75-80% of the array capacity) although this is not the case in the example shown.

It is clearly necessary to set a reasonable inverter threshold, consistent with the operation of the inverter. In some cases, it may not be possible to adjust the threshold values. However, system installers should check on the threshold level and adjust where necessary and possible to ensure that the system continues to operate at least down to 100 W/m<sup>2</sup> irradiance levels. Systems showing the best performance levels often operate at all irradiance levels above 50 W/m<sup>2</sup>.

#### 8.4.5 Shading of the Array:

Whilst inverter outages have been seen to cause the largest reductions in yield, shading of the array can also lead to significant losses. It is obvious that obscuration of part of the array will lead to a reduced output, since the irradiation received by the PV modules is reduced. However, because of the connections arrangements of most PV arrays, the loss in output is generally larger than the geometrical area of the shading might suggest. As a result, significant losses have been observed at several DFT sites as a result of array shading. There are only three DFT sites where the data suggests that none of the systems are shaded at any time of year.

There are two main causes of shading. Firstly, the array can be shaded by trees (or other vegetation) that are sufficiently tall and situated close to the array. These trees do not have to be in the PV system owner's garden, but can also belong to a neighbour, represent the border or a communal area of the estate or be sited on the street (council owned and maintained). Examples of all these situations have been observed in the DFT. Another obvious, but

important, characteristic of trees is that annual growth can exacerbate the problem and, in some cases, initiate it where the tree was not sufficiently tall to cause shading at the time of system installation. Thus it is necessary for the user to be aware of the effects of shading from trees and to take measures to reduce the shading where possible.

The second main cause of shading is another part of the building on which the array is mounted, for example a protruding roof or other items mounted on the roof (chimney, aerial, satellite dish etc). The common designs for terraced houses often result in some properties being set forwards and others set back, to break up the visual lines of the building and add interest. However, this also adds the potential of shading for arrays on roofs that are set back. Changes in roof height can also cause shading problems. Figure 63 shows an example of a shaded array on a single storey roof due to the adjoining two-storey house.



*Figure 63: Roof-integrated array with crystalline silicon roof tiles, where the left-hand side of the array is shaded by the adjoining building. At the extreme left of the picture some shading of the upper roof array can be seen.*

The extent of shading varies with both time of day and season. In some cases, it may only be experienced in winter when the sun is low in the sky, but in other cases may cause a problem all year round. Figure 64 shows an example of seasonal shading from one of the DFT sites, with the increase in shading in the winter months clearly shown. In this case, the shading source is situated to the south west of the array, causing the shading to occur in the afternoon. Shading can lead to losses of a few percent of output in minor cases to several tens of percent in severe cases. It is often quite difficult to quantify the losses that will be experienced from shading unless an appropriate software package is utilised.

Example of Seasonal Change in Shading Losses

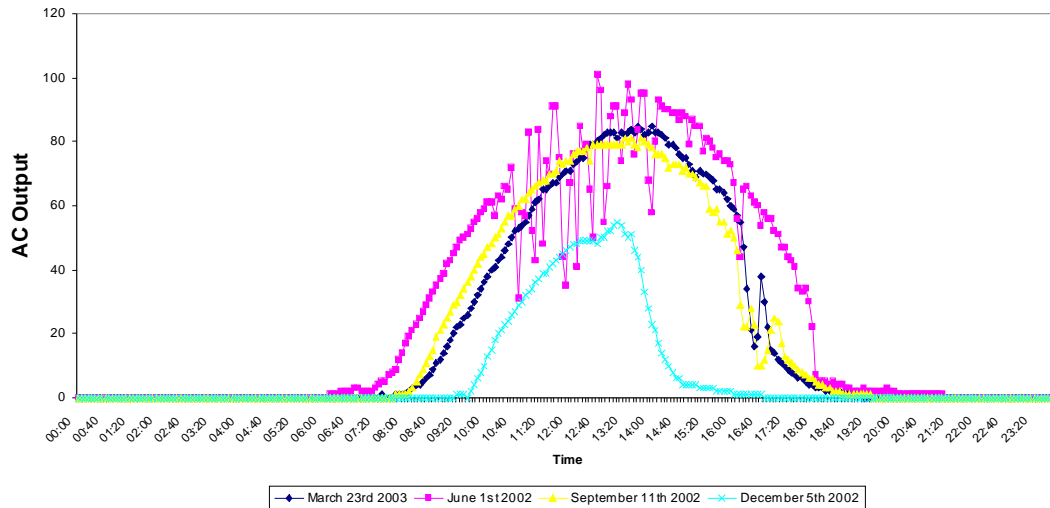


Figure 64: Example of the change in shading effect with season. In the summer, there is only a very small effect at the end of the day, whereas in the winter months, the output drops to very low values for almost half the day.

Since all system designers should be aware of the penalties incurred as a result of shading, it is perhaps surprising that so many of the DFT sites should have experienced losses from this source. However, it can be quite difficult to avoid all shading in an urban environment, especially when houses are closely packed (such as in terraced properties). It also seems that some of the project teams have ignored what should have been obvious sources of shading and failed to alter their system designs to minimise losses.

In future designs, three actions should be taken. Firstly, the system designers should take into account all sources of shading, particularly those related to self-shading from other parts of the building, and locate the array in an unshaded position wherever possible (even if this means reducing the size of the array by a small amount from the original intention). Secondly, where it is not possible to avoid shading, the array design in terms of the interconnection of the modules and the number of inverters to be used should minimise the effect of the shading. Where this incurs extra cost, the design will need to be optimised in terms of the value of the system output that is maintained in comparison to that extra cost. Thirdly, the system user must be made aware of the steps to be taken to ensure that shading does not increase through the lifetime of the system, including the regular pruning of trees and careful placement of any items in the proximity of the array. Where the trees belong to someone other than the system owner, it may be necessary to enter into negotiation with regard to restricting the height and therefore the shading effect.

#### 8.4.6 Module Rating:

Both of the two main parameters used to judge system performance, the annual yield and the performance ratio, include the module rating in the denominator of the calculation. This introduces an uncertainty in the values proportional to the uncertainty in the rating due to the spread in module performance in the production process. For large systems, it is quite common for measured parameters for each module to be provided to the customer, confirming the output. In the case of small domestic systems, it is very unusual to have confirmed outputs from the modules used. Where the output of the module is lower than the nominal rating, then reduced annual yields and performance ratios will be obtained. Conversely, if the modules perform better than the nominal rating, then higher annual yields and performance ratios will be calculated.

In the case of one of the DFT sites, the data suggest that the PV tiles making up the PV arrays have a considerably lower performance than the nominal rating. This means that the annual yield and performance ratio values are both reduced substantially even in the absence of any other major loss mechanisms. This led to several of the yield values in the 400-600 kWh range in Figure 53. This does not appear to be a widespread problem, being generally restricted to a single product and perhaps even to only some examples of that product. However, it is worth considering how best to establish that the initial PV product is performing to specification, without undue additional cost.

**8.5 Contribution to Building Loads**

All the PV systems in the DFT are grid connected, with their output going firstly to meet the loads of the building on which they are installed and any excess being exported to the grid. Having considered the electrical performance of the systems in previous sections, we now consider how much of the building load can be provided by the solar system. This can be expressed by a quantity known as the solar fraction. This is the overall output of the system as a percentage of the overall demand in a given period, in this case one year. It does not distinguish between electricity that is used in the house immediately and that which is exported with an equivalent amount being imported again at a later time, but expresses the total contribution that is made.

The solar fraction is, of course, highly dependent on the load levels and, in turn, on the lifestyle and habits of the occupants. Thus we tend to see a much wider variation in solar fraction than in the other performance parameters considered in this report. Figure 65 shows the aggregated solar fraction results from 15 sites, representing 230 systems and 382 individual values for annual solar fraction.

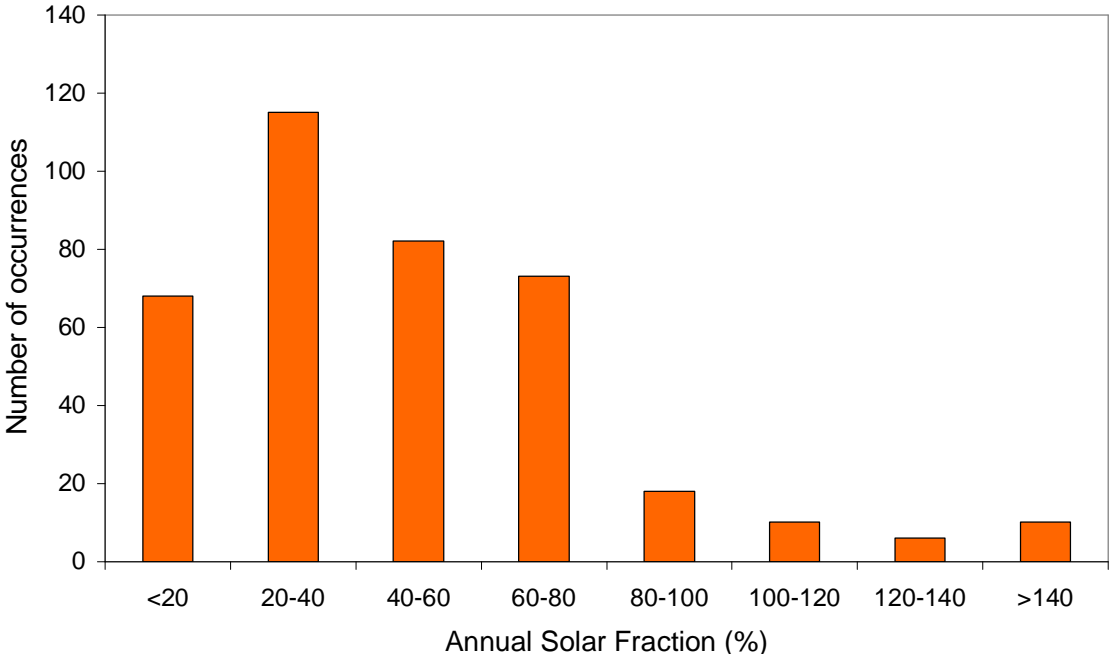


Figure 65: Annual solar fraction values for 15 DFT sites. The average system size is 1.6 kWp.

From Figure 65, it can be seen that there is a good spread of values in the ranges up to 80%, with significantly fewer values above this. Nevertheless, 12% of the values are in the categories above 80% solar fraction. The average solar fraction for the whole data set is 51%. This indicates that, even for a modest average system size of 1.6 kWp, the output from the PV

system can contribute a significant proportion of the building requirements across the year.

As previously considered with the annual yield values, Figure 66 shows the solar fraction values obtained for the sites in the different location categories.

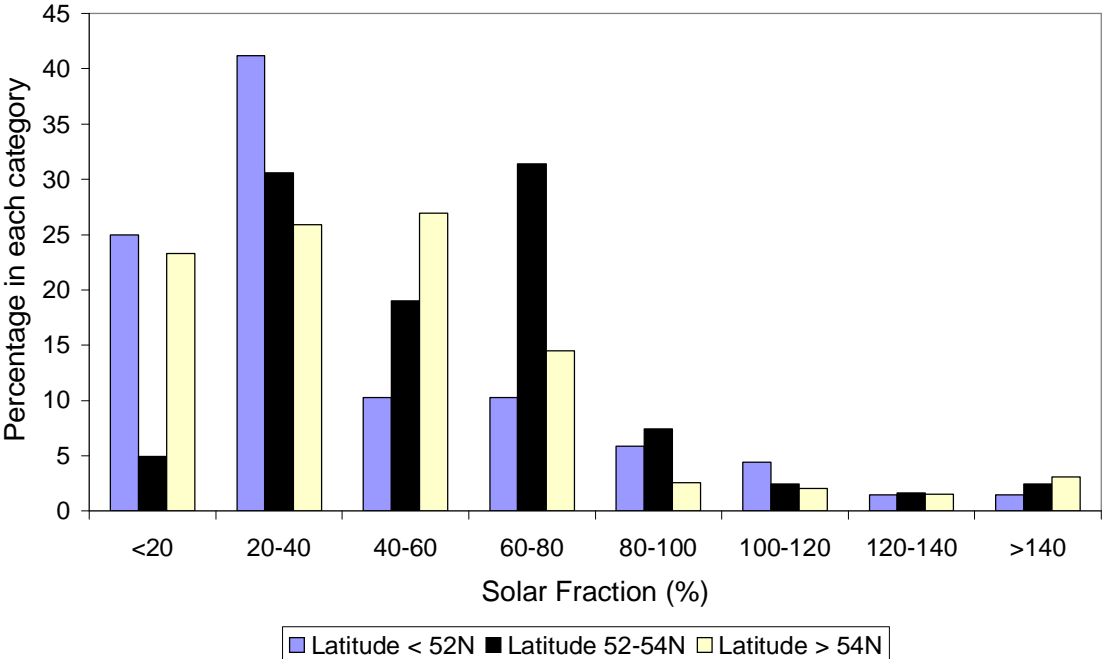


Figure 66: Variation of solar fraction with location. The average system sizes are 1.4, 1.5 and 1.7 kWp respectively for the three location categories. The occurrences are now expressed as a percentage to allow comparison.

As before, there is no clear trend in solar fraction as a function of location, with the value being dependent on the variation in building load as well as on system output. There is often a variation between sites depending on the nature of the general energy supply to the properties (especially in terms of space and water heating) and the type of occupant. However, there are also some wide variations in energy use between properties on the same site. Because none of these properties were monitored before the PV system was installed, it is not possible to draw definite conclusions about any modifications to energy usage as a result of having renewable electricity generation other than the results given in the post occupancy survey (section 6.9).

### 8.6 Summary

The DFT has provided a large amount of data on the performance of the PV systems installed under the programme and the analysis above has considered both the overall performance parameters and some specific behaviour. Whilst it has necessarily concentrated on the reasons for reduced performance in some of the systems, the DFT has many examples of systems that are operating in line with expectation and providing annual yields above 800 kWh/kWp.

Analysis of the loss mechanisms shows that inverter outages and shading problems are responsible for the highest losses, but that dropout of the inverter due to high grid voltages is also a significant cause of loss. Less severe but still significant losses result from incorrect choice of the inverter threshold. Suggestions for reducing the system losses, both in the first instance and across the lifetime of the system have been provided.

The DFT has also allowed the contribution of the PV system to the building load to be investigated with a large sample of systems on several sites around the country. The analysis

shows that, even for fairly small system sizes of around 1.6 kWp, a significant fraction of the building demand can be met by the PV system, either directly or indirectly. It has been seen that the majority of systems provide between 20 and 80% of the building load with an average of 51%.

The monitoring of the PV systems in the DFT has allowed the identification of typical system levels, the investigation of dominant loss mechanisms and the consideration of how both users and designers can take actions that would minimise the system losses. It is expected that the DFT data will continue to be a research resources as new system designs and procedures are developed.

## 9 Dissemination

### 9.1 List of outputs (as of January 2006)

The outputs of the project have been numerous. They have aimed to address frequently asked questions and to collate and disseminate the lessons learnt. This has been achieved through various media, as described below.

#### 9.1.1 Annual Technical Reports including the Final Technical Report

The annual technical reports are detailed and are based on on-going experiences within the programme. This report is the final technical report containing the conclusions of the programme. These reports are available to the general public, via the DTI website. This website and the reports themselves have been further disseminated during events, such as the workshop, and other DFT publications and conference papers, detailed within the General Publications listed at the end of this section.

Annual Technical Report		Published in	Page No.	Content	Target audience	Format
No	Period covered					
1	2000-01	2002	42	Technical report covering the first five installation within the PVDFT in regards to appearance, architectural integration, fixing methods and cost effectiveness of these.	PV industry, architects, PV designers, researchers and building owners and developers.	PDF
2	2002	2003	41	Technical report covering eight projects spread over 13 locations, in regards to appearance, architectural integration, fixing methods and cost effectiveness of these. It also highlights monitoring system issues emerging throughout 2002.	As above	PDF
3	2003	2004	52	Technical report reviewing a further 13 projects in regards to appearance, architectural integration, different fixing methods and cost effectiveness, as well as monitoring activities and initial results of the data analysis activities.	As above	PDF
4	2004	2005	62	Technical report covering the last two installations as above. It also presented the results of the DFT developer or post selling survey, monitoring activities and more	As above	PDF

Annual Technical Report		Published in	Page No.	Content	Target audience	Format
No	Period covered					
				detailed system performance analysis.		
5	2000-2006	March 2006	~100	Final technical report to cover the whole period summarising lessons learnt in regards to buildability, reliability, maintainability and operating performance of domestic based PV systems. It will also feature detailed results of the end user survey and final performance analysis.	As above	PDF

### 9.1.2 Bi—annual Newsletter

The bi-annual newsletters (six in total, with four six pages long and two at 8 pages long) were produced from November 2001 to May 2004. These were used to raise awareness of the programme and provide information on the projects and activities within it.

Each Newsletter had a print run of around 2000 and was widely circulated within the PV and building industries (PV-UK, IEA PV mailing list, DFT and LSFT contacts, SAP 100 Builders Club, Association of Environmentally Conscious Builders, National House-Building Council (NHBC), CIBSE Journal, Architects Journal) and other relevant groups, i.e. housing associations, Government Offices of the Regions to raise awareness of the programme. Additional numbers were circulated electronically to all the PVDFT members and other general contacts with a potential interest in domestic PV installations.

Newsletters		Published in	Page No.	Content	Target audience	Format
No	Period covered					
1	2000	Nov 2001	6	Introduction to the DFT and details of the first four projects including description of technology used and installation methods with photos. All the newsletters contain statistics of the field trial and sources of further information for readers.	PV and building industry, other relevant groups such as housing associations and Government Offices of the Regions.	PDF and printed (2000 copies)
2	2001	May 2002	6	Details of a further four completed sites.	As above	PDF and printed
3	2002	Nov 2002	8	Details of lessons learnt so far from installations completed, and	As above	PDF and

Newsletters		Published in	Page No.	Content	Target audience	Format
No	Period covered					
				a description of the next five installations since the last newsletter. A workshop summary is included from the workshop held on 13 <sup>th</sup> June.		printed
4	2002-2003	May 2003	8	An overview of the field trial and update of the current situation. Further information is given on seven completed sites. A summary of the performance monitoring and analysis is also given with details of some issues that arose.	As above	PDF and printed
5	2003	Nov 2003	6	An update of progress is provided, and specific information is given on four sites. A review of monitoring issues and data analysis is included and a focus is given on some specific issues arising. The newsletter also contains information on the second workshop.	As above	PDF and printed
6	2003 - 2004	May 2004	6	Details on the two last sites are included. A section on performance and analysis draws on analysis of the data being received so far. Some specific technical issues are focused on such as the introduction of G83. The newsletter also updates readers on the announced extension to the programme and progress with ROCs.	As above	PDF and printed

### 9.1.3 Surveys

Two surveys were carried out. The Post Selling or Saleability Review results were outlined in the Annual Technical Report 4 – 2004 and have also been summarised in section 6.1. The Post Occupancy Survey measures the level of acceptance by owner occupiers/tenants and the ease of monitoring. This included capturing whether occupiers noticed a reduction in their electricity bill, level of maintenance, perceived environmental benefits, prospect of Building Integrated PV (BIPV) installation without subsidies and more. The results are summarised in section 6.9. Both surveys have also been presented in technical papers, detailed within the General Publications listed at the end of this section.

### 9.1.4 Case studies

Case Studies, aimed at housing developers/associations, have been produced on four of the twenty-eight projects: These comprise two shorter two page studies for Newbiggin Hall Estate and Campkin Court, and two longer 4 page studies for Pinehurst and Corncroft. The aim is to illustrate different types of installation, i.e. integrated as part of a renovation programme, module roof-mounted and integrated within new-build, and flat roof installation, whilst reviewing any problems faced and how they were overcome. They will be disseminated electronically similarly to the newsletters.

Case studies	Published in	Page no.	Content	Target audience	Format
Campkin Court	March 2006	2	Two page summary of project highlights and lessons learnt.	For practical advice for similar projects.	PDF on website
Newbiggin	March 2006	2	Two page summary of project highlights and lessons learnt.	As above	PDF on website
Pinehurst	March 2006	4	Four page summary of project highlights, performance results, team and householder feedback and lessons learnt.	As above	PDF on website
Corncroft	March 2006	4	Four page summary of project highlights, performance results, team and householder feedback and lessons learnt.	As above	PDF on website

### **9.1.5 Good Practice Guides**

A Good Practice Guide is being produced in two parts: Part 1 Project Management and Installation issues and Part 2 System Performance and Design Issues. These cover the main issues which are of interest to the industry and developers. They are key documents in the dissemination of the results of the programme and will be available from the DTI website as well as widely circulated to the industry and professionals for future reference.

### **9.1.6 Workshops**

Two workshops were held by the PV DFT consortium as part of the programme, a specific construction workshop in June 2002 and a workshop covering the lessons learnt to date in November 2003.

The Construction Workshop was held on June 13<sup>th</sup> 2002. This was an invited workshop with an attendance of 56 delegates. Eleven of the 56 were from project teams involved in the field trial. Feedback from the afternoon sessions mainly focused on regulatory and agreement issues. As many delegates had direct knowledge of at least one PV installation, the discussion was anticipated to increase the understanding and show the scale of potential barriers during the approval process. However most delegates found the procedures straightforward. There was only one example where problems arose trying to secure the necessary types of agreements.

The second workshop entitled “We do it on the roof! Real lessons learnt” was held on the 17th November 2003. There were presentations in the morning which reviewed the programme as a whole and then in the afternoon some of the Project Teams presented their projects. In addition there were posters from other project Teams displaying their projects. There were 75 delegates with more than 50% from outside the programme. All of those who completed a delegate questionnaire rated the event good, very good or excellent. The workshop found that there was some lack of understanding about the process connecting to the grid, of selling electricity and the associated negotiations required on behalf of the Housing Associations and other attendees at the workshop. The changes in terms of tariffs are felt to be hard to follow. It was universally considered that there needs to be continued support to install PV unless the prices for PV fall significantly, this could either be in the form of grant or through specific high tariff for PV generated electricity (interest in German system expressed) although recognised that this would need to be politically led. Delegates were keen to have the results from the programme disseminated as quickly as possible, possibly by setting-up a forum of some kind to keep people up to speed and exchange information.

### **9.1.7 Data dissemination and Discs**

Owing to the quantity of data and attendant processing required, the intention is to publish data for around half of the systems. Also any systems where errors in data make the results unfeasible will be excluded. The data will be published on one or more widely accepted media (eg CD ROMs, DVDs, FTP site), the exact format is to be decided.

Data has been provided to third parties for specific projects in line with the programmes confidentiality agreement.

## **9.2 General Publications**

There have been numerous presentations made regarding the DFT programme world wide. The papers and presentation that have been made throughout the life of the programme are listed below. There were also a number of short PV related articles featuring in UK building

magazines. During the early stages of the programme various presentations and meetings were held with the PV industry and other stakeholders.

1. *The Sun will still shine* - initial findings of PV and lifestyle changes by 2020, Monika Munzinger at “Energy through the Looking Glass” held by Lancaster University, 20th September 2005.
2. *PV perceptions, lessons for the future: user and developer views of grid connected domestic PV systems in the UK*, Monika Munzinger, Frances Crick and Gillian Bates, Chris Martin and Nicola Pearsall, Proc. 20th European Photovoltaic Solar Energy Conference, Barcelona, 2005.
3. *An examination of load contribution and export profiles for UK domestic PV systems*, Nicola Pearsall, Kathleen Hynes, Chris Martin, Monika Munzinger and Frances Crick, Proc. 20th European Photovoltaic Solar Energy Conference, Barcelona, 2005.
4. *The PV Domestic Field Trial (DFT) Programme: Progress and Results*, Frances Crick, Monika Munzinger, Nicola Pearsall and Chris Martin, Presented at PVSAT2 (UK Solar Energy Society), Loughborough, UK, April 2005.
5. *Performance and Reliability Analysis in the UK Photovoltaic Domestic Systems Field Trial*, N. M. Pearsall, K. M. Hynes, C. Martin and M. Munzinger, Proc. of the 31st IEEE Photovoltaic Specialists Conference, Orlando, Florida, January 2005
6. *The UK PV Domestic Systems Field Trial – Widespread PV installations in the UK: Real lessons learnt*, Frances Crick, Monika Munzinger, Nicola Pearsall, Chris Martin and Jonathan Bates, Proc. 19th European Photovoltaic Solar Energy Conference, Paris, 2004, p.3114-3117.
7. *The UK PV Domestic Field Trial- lessons learnt*, Nick Davies, Monika Munzinger, Eurosun Proceedings; Freiburg June 2004
8. *Solar Energy in the local community: Solar Energy and beyond, a review of two funding programmes*, Frances Crick, Monika Munzinger and Chris Roberts Presented at IMechE Conference, Renewable Power in the Community, March 2004.
9. *System Monitoring and Performance Analysis in the UK PV Domestic Field Trial*, N. Pearsall, C. Martin, K. Hynes, M. Munzinger and F. Crick, Proc. 19th European Photovoltaic Solar Energy Conference, Paris, 2004, p.2976-2979.
10. *The UK Domestic Photovoltaic Systems Field Trial - Analysis of Design and Performance*, N. M. Pearsall, M. Munzinger, F. J. Crick and K. M. Hynes, Proc. of the 3rd World Conference on Photovoltaic Energy Conversion, Osaka, Japan, May 2003.
11. *UK PV Domestic Field Trial – Installation Status and Performance Review*, N. M. Pearsall, M. Munzinger, K. M. Hynes and F. J. Crick, Proc. of PVSAT (UK Solar Energy Society), Loughborough, UK, 3-4 April 2003.

## 10 Management issues

The key responsibilities of the PVDFT Consortium, as set out at the start of the programme, were:

- to complete site visits and investigate issues during the construction and commissioning of both the PV system and monitoring system
- to assess and comment on Project Team reports (design, procurement, installation, commissioning, progress reports over 2 years)
- to oversee data collection
- to carry out data analysis
- to aid Project Teams with troubleshooting, where required
- to collate the key lessons learnt
- to disseminate this information.

Many installation and technical issues were explored during the early period of the DFT, when developing checklists for the various stages, including design, procurement, installation, commissioning and monitoring.

Still the majority of sites involved in the PV DFT experienced various delays and therefore most were unable to adhere to the original timescales. Even though this was anticipated to a certain extent, the complexity of issues encountered and times required to resolve these and disseminate findings had serious implications on meeting project deadlines. There are many reasons which led to these delays and these have been discussed previously. However the main contributing factors are the level of monitoring required, which had never been done before, combined with the large amount of PV systems and subsequently individuals involved.

Other factors were that quite a lot of project team contacts changed whereby the successor usually took some time to get up to speed with the DFT requirements. There also seemed to be a certain degree of lack of understanding what these requirements were and / or they seemed to be of minor importance to project teams. This is somewhat understandable when compared to other issues project teams were faced with, i.e. limiting disruption to tenants, allowing householders to move in smoothly, etc. Still it was somewhat frustrating to experience slow response rates particularly when it came to trying to organise site visits and provide sample data.

This led to a number of additional activities the PV DFT Consortium had to carry out, which were over and above the originally troubleshooting tasks. The issues leading to these additional activities have been discussed previously. One other point is made here: In general implementing data collection was more time consuming than anticipated (section 7.6). There was therefore a longer gap than expected between commissioning and the start of data collection, which often affected a project's contract periods and overall cash flows.

## 11 Conclusions and recommendations

The UK Photovoltaic Domestic Field Trial (PV DFT) represents the first wide spread monitoring of PV systems in domestic buildings in the UK. Throughout the programme groups of domestic buildings were monitored through all phases; from design, through building integration, commissioning, and operation, allowing information on buildability, reliability, maintainability and PV performance data to be collated under real UK situations, including climate and operating conditions.

Good Practice Guidelines have been produced based on the lessons that have been learnt from the PV DFT Programme. These are in two parts: Part 1 – Project Management and installation Issues and Part 2 – System Performance Issues. The former provides detailed guidance for domestic PV installations in general and for specific types of installation, i.e. integrated new build. The latter provides an outline of what to look out for and how to complete a PV building project for maximum system performance. Key issues are briefly summarised here but these two good practice guidelines should be reviewed for a more detailed discussion.

In terms of the management and installation of projects the lessons learnt from all stages of the design, construction and PV installation process have been loosely categorised into three categories: communication, site/location and good practice. Many issues raised were recognised as important existing issues within the construction industry in general although clearly having a heightened importance when involving the introduction of a new technology such as PV into these situations.

Communication has remained a key issue within the DFT programme. Its importance cannot be over stressed as most projects experienced minor problems, and quite a few major ones, due to poor communication, leading to delays and additional costs. This also relates to the need to make sure that different trades understand each others' specific requirements, calling for better dissemination between the PV and construction industry, as well as other associated organisations or clients.

Efficient and effective contractual arrangements and organisation is related to this and is also very important. It was noted that there are a wide range of conditions and requirements between major clients that contractors need to meet, e.g. Health & Safety requirements, to become an approved contractor for some clients such as local authorities. It is important that the PV industry is aware of these various requirements enabling them to meet the needs of different clients without incurring extra cost. This relates to effective communication as well as the need for the PV industry to understand more clearly the operation of the construction industry.

Understanding of PV systems, their layouts and the operational requirements of the component parts, including DC wiring and Balance of System (BOS) equipment siting, is crucial to effective and efficient installation as well as operation. Providing information and training to project teams, householders, caretakers etc. is an important step in this process. Experience throughout the DFT has shown that it is crucial for inverters and displays to be easily accessible, as this will avoid any follow on problems when it comes to maintaining the system. Therefore effective layout combined with precise and easy to understand handout documentation will make monitoring of the system operation and subsequent maintenance that much easier. This also highlights the need for better customer services, making sure client and householder demands in regards to installation and operation are understood and met. One needs to keep in mind that most householders or other maintenance people (caretaker)

are new to the operation and maintenance requirements of PV.

Problems have occurred with the process of connecting to the grid, although this has improved somewhat for small systems with the introduction of G83. Difficulties include identifying a suitable electricity supplier and securing ROCs indicates that there is considerable scope for streamlining the process of connection, not just with small scale systems but also with those dependent on G59. The process is also poorly understood, not just in terms of technical issues but also the possible financial gain, which can deter those interested in developing systems.

System performance of the PV systems was assessed by a detailed monitoring regime. Early in the programme the requirements for monitoring were established, this work helped to define the monitoring guidelines and has provided invaluable experience and information for the large-scale monitoring of PV systems on widespread sites, in relation to ensuring comparable and usable data.

The analysis has considered both the overall performance parameters and some specific behaviour. Whilst it has necessarily concentrated on the reasons for reduced performance in some of the systems, the DFT has many examples of systems that are operating in line with expectation and providing annual yields above 800 kWh/kWp.

Analysis of the loss mechanisms shows that inverter outages and shading problems are responsible for the highest losses, but that dropout of the inverter due to high grid voltages is also a significant cause of loss. Less severe but still significant losses result from incorrect choice of the inverter threshold. Suggestions for reducing the system losses, both in the first instance and across the lifetime of the system have been provided. The DFT has also allowed the contribution of the PV system to the building load to be investigated with a large sample of systems on several sites around the country. The analysis shows that, even for fairly small system sizes of around 1.6 kWp, a significant fraction of the building demand can be met by the PV system, either directly or indirectly. It has been seen that the majority of systems provide between 20 and 80% of the building load with an average of 51%.

Generally PV modules only require a low level of maintenance, which is supported by the limited amount of maintenance required within the DFT. However a number of errors in regards to the BOS and monitoring equipment including inverters and meters, were picked up due to the specific detailed monitoring in place. This therefore shows how crucial regular checks are in order to ensure continuous operation, hence maximise benefits in regards to output, potential export and refunds.

The industry does recommend that, for example, the inverter is checked daily or the yield is recorded on a monthly basis. These are all fairly easy to undertake tasks. However given the present low level of understanding it might stretch householders' capability, especially when it comes to more technical, half yearly checks of junction boxes, surge arrests and wiring. Routine checks like these could also be seen as a nuisance by householders and suggest that PV systems are actually quite frail. Still these shouldn't represent an obstacle as long as householders and organisations planning to install PV are aware of these requirements prior to doing so as well as integrate best practice solutions for system design and layout.

Overall results show that the level of end user acceptance is very high but at the same time there is a clear lack of understanding how they work and might impact on their (daily) routine, electricity costs and environmental credentials. In general the DFT has shown that householders are very interested in their PV system but also somewhat frustrated by the lack

of easy to understand information, specifically in regards to signing up to buy-back contract. The results have also shown that in order to maximise the system return some behavioural changes are necessary. For example using appliances during periods of PV production, as well as minimising overall electricity consumption by using energy efficient appliances and light bulbs. Potential PV end users should however be enabled to adopt these easily through service contracts and easy-to-understand hand-outs.

Project cost information was analysed for all of the projects covering new-build and retrofit sites and their different systems and installation types. Costs were analysed on an electricity cost per kWh and a system cost per Wp.

Based on a system lifetime of 25 years the cost of the PV generated electricity was found to be between 20.9p/kWh and 184.7p/kWh with an average of 47.5p/kWh. Out of these 25 sites 18 actually came out at below the average. Taking account of any underperforming systems reduced both the average and maximum £39.1p/kWh and 77.8p/kWh respectively. This is still well above current electricity prices at around 8p/kWh or the average buy-out contract tariffs (at about £7p/kWh). However these figures are based on real installations and do show that the average is an improvement to the average generally quoted at around 50p/kWh.

The combined average costs within the DFT for retrofit sites were £8.03/Wp (£5.90/Wp) whereas the new build sites were £7.24/Wp (£6.25/Wp). The figures in brackets give average costs excluding management and monitoring expenses. Comparison to the latest costs within the Major Demonstration Programme (MDP) where retrofit systems average at £6.34/Wp and new build installations at £7.40/Wp, would indicate that retrofit projects have actually realised higher cost reductions than new-build projects. Still one needs to keep in mind that a direct price comparison between the DFT and MDP is not possible, due to the different approaches of gathering and analysing data.

It was also found that there was an overall trend of decreasing cost within the DFT, which correlates to figures within the MDP. This trend of decreasing costs is a sign that overall the PV market has gained confidence and is moving towards a more streamlined process. The lower costs for new build frame mounted system indicates that cost savings can be achieved when integrating PV, since the costs of site works, storage and scaffolding are shared by other construction works. Good planning and communication can help to further reduce costs.

As part of the PV DFT two surveys have been carried out, the Post Occupancy and the Post Selling Survey. The findings indicate that most developers participating in the PV DFT were supportive of PV, but saw cost as the major obstacle to its' wider implementation. The cost issue is a well known barrier to the uptake of PV. It is therefore encouraging, to see so that the majority of developers (88%) are considering to use PV modules in future. It would also be fair to say that the field trial has helped to shape developers' views and that it contributed positively to the development of the PV market in the UK.

About 40% of developers not involved in the PV DFT believed that PV decreases the aesthetics of a property. The construction industry therefore still perceives PV to be aesthetically unpleasing and most possibly to be an unsuitable building material. However developers within the PV DFT felt that PV enhances or at least does not detract from the appearance of a property. They also stated that the installation overall went fairly smoothly and that participation within the PV DFT helped to shape their positive view. This therefore counteracts the common believe that PV modules are unsightly or complex to install.

Overall the programme has been very successful and achieved its aims: important lessons

have been learnt and disseminated providing learning opportunities for key players involved in the process of PV installation and use, as well as invaluable performance data for a wide range of real installations across the UK. Data has been gathered both in the form of experiences from design and installation and from system performance monitoring. This is the first project of its kind and this information has permitted the development of key documentation and recommendations for the industry as a whole.

Overall the findings indicate that PV is still very much a niche activity for a few market players. This niche position is sometimes overlooked by organisations and individuals involved in the renewable energy industry. The key barriers remain costs and a limited amount or lack of end user information. Cost reductions are being tackled by grant and similar programmes. Still more information about benefits needs to be made available, preferably in a way easily understood by the general public.

Since this project started the PV industry as a whole has moved on and matured somewhat with many more products on the market, including more sophisticated integration methods. Most of these are however produced for the European or world-wide market and the compatibility issues that this caused in the UK have been highlighted. Further work on this subject is merited.

Specifically for the monitoring of the PV systems which has allowed the identification of typical system levels, the investigation of dominant loss mechanisms and the consideration of how both users and designers can take actions to minimise these losses.

In summary the wealth of information obtained from the PV DFT has been used to refine the guidelines for monitoring work, to improve the design of PV systems, to develop best practice guidelines, recommendations and case studies; and to inform the buildings and electricity industries about the suitability of the technology. It has also provided accessible examples of a wide range of domestic PV installations for both the general public and the planning authorities. Data has provided information on real installations, output and problems within the UK.

The PV industry should be further encouraged to implement a “Good Practice” approach with the client involved at every stage, as this can lead to overall cost savings on projects. The documents produced within this programme, especially the Good Practice guides will therefore be effectively disseminated.

Considering that quite a lot of clients are construction companies there is also scope for providing information to the PV industry on the tendering and contract processes used in the building industry. This would allow the PV contractor to adopt their contractual and finance systems accordingly.

There is scope to develop appropriate general guidelines for the market assessing the suitability of roof structures for PV array mounting. This is an area that causes considerable concern to potential developers.

Performance issues have also been raised by the programme whereby inverter outages and shading problems are responsible for the highest losses. Furthermore dropout of the inverter due to high grid voltages is also a significant cause of loss. Less severe but still significant losses result from incorrect choice of the inverter threshold. The industry needs to be made aware of these issues and ensure they are able to avoid these. Any potential performance issues should also be discussed with clients, where appropriate. This requires considerable

and targeted dissemination of these latest results via workshops, conferences and articles in relevant building and renewable magazines.

The connection of the system to the grid and particularly the grid voltage at site can have a significant influence on system performance. It is not always easy to test this at the time of installation, as it may be the wrong time of year or the wrong load conditions to evaluate any potential problems. However, it is suggested that, where there is a reasonable expectation of problems, the commissioning tests consider the grid voltage level. They should also be carried out over a period of time rather than consisting of only instantaneous values, in order to provide a possibility of observing the problem. The way in which commissioning tests could identify and address this problem requires further development. The data analysis has highlighted that this can be a significant factor in system performance but the development of a solution was beyond the scope of the project."

There is considerable scope to investigate and develop with the PV industry the offer of a service contract either to the individual householder or housing association, in order to guarantee maximum operation of the PV system. This could involve the installation of suitable PC software allowing the inverter data to be accessed via dial-in modem. This allows a number of functions such as receiving automatic error messages or overall performance figures. Thereby avoiding actually having to visit the site but adding to overall equipment costs. Interested householders might even like to install more sophisticated monitoring software allowing automatic downloads of data and operating and performance checks via the PC.

Basic monitoring systems and review of performance, could be included in any such service contract. These are important not only to check system performance but also to identify system failures thereby minimising system losses. Such contracts would be especially useful for end users who are not the purchasers of the PV system, i.e. tenants in Housing Association properties.

The whole process of connecting to the grid, finding a supplier to buy the electricity generated and the sale of ROCs should be improved in consultation with the industry (Ofgem, DNOs and suppliers). In general what often happens when signing up to a buy-back contract is that the electricity supplier claims the householders' renewable obligation certificate/s (ROCs) through Ofgem against a commission. Householders are also able to register with Ofgem themselves and therefore claim their own ROCs.

However although the application process through Ofgem has been simplified it seems unreasonable to expect householders to grasp the concept of ROCs when many of them are struggling to understand their PV system.

Options might include:

- Electricity suppliers offering a uniform tariff for green electricity (linked to ROCs) with simple guidance on how to sign up and expected benefits.
- A system to allow the householder to see the benefits clearly expressed in pounds on the electricity bills.
- Examination of the way in which householders pay for their bills. It is near to impossible for card meter users to change suppliers and get paid for exported electricity because they do not have a contract with the electricity supplier, i.e. no bills are involved. It is exactly these end users which would benefit most by receiving refunds. In a way they might also be the most difficult to address as they generally have other more pressing concerns than energy efficiency or renewable energy. Yet they are also the ones looking to cut down on costs and would probably be most

receptive to any benefits especially if offered as an easy to take up package through the housing association.

Bearing in mind that any such consultation will take time the existing system should be fully documented, in an easily understandable form, perhaps via a website that can be easily updated as suppliers change prices, etc. and disseminated.

End user understanding and hence effective system use and operation requires further support. Recommendations to develop the necessary documentation, specifically describing issues such as how to carry out simple visual checks and appropriate instructions on how to interpret readings, should be made to the PV industry. This should be supported by appropriate service contracts and simple easy-to-understand hand-out. It might even call for details being provided in a similar fashion to the properties' heating system. After all the PV system is intended to operate for at least 20 years and should therefore be seen as an integral part of the building services. It would also ensure that the information was readily available to any new occupiers.

The extensive DFT data must be allowed to continue to be used as a research resource. Its inclusion in the International Energy Agency (IEA) Task 2 database provides an important and widely visible availability.

# Appendix 1

## SOLAR ELECTRIC DOMESTIC FIELD TRIALS

### A QUESTIONNAIRE FOR DEVELOPERS, HOUSING ASSOCIATIONS AND SELF-BUILD

The houses incorporating solar electric (photovoltaic) systems within your development are part of an important programme or field trial considering the use of photovoltaics in domestic buildings. This trial, funded by the Department of Trade and Industry (DTI), is the first of its kind demonstrating this technology in the UK. The overall results of the trial will draw out the factors affecting widespread implementation of photovoltaic systems and will be used to decide how best to use the technology in the future. This questionnaire is part of that process.

The aim is to investigate your perceptions of the technology, its integration into the buildings in your development and “value” or “worth” for your customers.

Your group is an important link in the chain which forms the field trial. We are not asking for any detailed company information and any responses/information that you provide will be kept in strictest confidence, used solely for the purpose of the trial. It will not be passed to any third parties. Please answer as many questions as possible, leaving any that you do not want to/can not respond to. Some of the questions below might not be relevant to you specifically, especially if you are a Housing Association, please indicate this by putting a “N/A” after the relevant questions.

Thank you for your time in completing this questionnaire. Your views and responses are important to us and your help is greatly appreciated.

#### **The houses in your development**

1. How would the houses in your development/the project be characterised  
Size:  
Style:  
Price range  
Other: (social – specification, etc.)
- 

#### **System costs on the houses in your development**

2. Did you charge more for the PV houses in your development because they had photovoltaic systems installed?

Yes/No/Not sure  
If no, why not?

---

3. If yes, how much more?  
Less than £3,000  
More than £3,000 but less than £6,000  
More than £6,000 but less than £10,000  
More than £10,000

*To assess the level of any extra charge*

4. If no, would you now be willing to charge more for a house incorporating a photovoltaic system? (

Yes/No/Not sure  
If no, why not?

---

5. Have the PV houses sold/become occupied more readily than others?

Yes/No/Not sure  
If so/if not are there other reasons that have affected their sale?

---

**Awareness of PV and the issues involved/perceived**

6. What was the general level of purchaser/tenant interest and prior knowledge about PV?

Good/Some/A little/None/Not sure

7. Are purchasers/tenants wary of the maintenance or other aspects? Can you estimate how many, %?

Maintenance

Other

Number? \_\_\_\_\_

8. Are purchasers knowledgeable about the cost and run-cost benefits? Can you estimate how many, %?

Yes/No/Not sure

Number? \_\_\_\_\_

9. Are purchasers knowledgeable about the environmental benefits? Can you estimate how many, %?

Yes

No

Not sure

Number? \_\_\_\_\_

10. Have you used the presence of PV in the sales material/tenant information to encourage people to buy/become tenants?

Yes

No

Not sure

**How it looks**

11. Do you think the photovoltaic systems have enhanced the appearance of the houses or made it worse?

Enhanced it

Made it worse

Made no difference

Does it matter if it looks worse

**What others think**

12. Do visitors to the development comment on the panels on the roofs of the houses with photovoltaic systems without it being mentioned to them?

Yes

No

13. If yes are comments predominantly positive or negative?

Positive

Negative

If you can recall any specific comments, either positive or negative, please add them here

**Using photovoltaics on the houses in your development**

14. How did the decision to use photovoltaics on the development come about? Was it led by you/ photovoltaics company, i.e. supplier/installer?

15. What problems have you faced? Delays, maintenance issues, extra costs (bear in mind demonstration project)

16. Have you been happy with the PV supplier/with the handover documentation?

Yes

No

If yes, what did you particularly like?

---

If no, what did you particularly dislike/why not?

---

17. How could the PV supplier have done things better/what improvements would you like to see?

18. Bearing in mind that this is a demonstration programme was it more or less problematic than you expected?

More

Less

19. In hindsight do you think that these problems could have been avoided?

20. How has this affected you views of using the technology in the future?

21. Would you consider using PV on your houses again in the future (with or without grants/price reduction)?

Yes

No

If yes, why? \_\_\_\_\_

If no, why not? \_\_\_\_\_

**Finally**

22. Which of the following best describes your feelings about having a photovoltaic systems on your development? (tick one answer only)

I like it a lot, it looks good and is a great idea, there should be more systems on other houses

I quite like it although I have reservations about some aspects of it

It's OK, there are some aspects that I like about it and some that I don't

I don't like it much, although there are one or two positive aspects

I don't like it at all and would prefer not to have used it on this development/these houses?

23. What aspects do you like/dislike about it?

Ideas: Can be sold as money saving/good for the environment, Visual impact

Visual impact, Maintenance problems, Spending tax payers money

Other

24. Do you think the use of photovoltaic systems should be more widespread?

Yes

No

If no, why not? \_\_\_\_\_

25. Do you have any other comments about the system?

---

**Please return all completed questionnaires to:**

Monika Munzinger, BRE, Energy Technology, BRE Ltd. Garston, Watford, WD25

9XX, [munzinger@bre.co.uk](mailto:munzinger@bre.co.uk)



---

**Project team use only**

FES Contract Number \_\_\_\_\_

General site description \_\_\_\_\_

Contact spoken to: \_\_\_\_\_

(Name, Company/Group name, Position/Project Team)

Site type (who are houses for)

## Appendix 2

### Solar Electric Domestic Field Trials

#### A questionnaire for tenants/owner occupiers

Your house is part of an important programme or field trial considering the use of solar electricity (photovoltaics) in domestic buildings. This trial, funded by the Department of Trade and Industry (DTI), is the first of its kind, demonstrating this technology in the UK. The overall results of the trial will draw out the factors affecting widespread implementation of solar electric systems and will be used to decide how best to use the technology in the future. This questionnaire is part of that process. The aim is to investigate your perceptions of the technology now installed on your house. You are an important link in the chain which forms the field trial.

We are not asking for any detailed personal information and any responses/information that you provide will be kept in strictest confidence, used solely for the purpose of the trial. It will not be passed to any third parties.

Please answer as many questions as possible, leaving any that you do not want to/can not respond to. Just 10 minutes of your time is needed to complete this questionnaire.

Thank you for your time in completing this questionnaire.

Your views and responses are important to us and your help is greatly appreciated.

#### The solar electric system on your house

**1** When did you learn/realise that your house had/was to have a solar electric system on the roof?

I was approached at the concept stage

When it was installed

When you purchased/moved into the property

More recently than either of the above

Not sure

**2** Do you know how long the system has been on the roof

of your house?

Yes \_\_\_\_\_ years \_\_\_\_\_ months

Not sure as previously installed by

landlord/housing

association/previous owner

**3** How long have you lived in the house?

\_\_\_\_\_ years \_\_\_\_\_ months

#### Understanding the system

**4** How much do you know/understand about your solar electric system?

A lot An average amount

A little Nothing

**5** Who explained it/provided you with information about it?

Housing association/landlord Property developer

Previous owner Installer

Friend or family

Other (please state who)

**6** Are you satisfied with the explanation given about your solar electric system?

Yes No

If no, why not?

**7** Does your solar electric system produce electricity during the:

Day? Yes No

Night? Yes No

**8** When does your solar electric system produce most electricity?

On bright sunny days

On dull overcast days

Not sure

**9** In your house where is the display which indicates how much

your solar electric system is producing?

In the hall Next to the fuse board

Not sure

Other (please specify)

**10** How often do you look at your display showing what the

system is producing?

Never Once a day

Once a week Once a month

Other (please specify)

**17** Would you buy a house incorporating a solar electric system again?

Yes No Not sure

Why/why not?

#### Solar electricity costs

**18** What does the electricity produced by your solar electric

system cost when compared to that produced by conventional

power stations?

A lot more A little bit more

The same A little bit less

A lot less Don't know

**19** Before starting this questionnaire did you know that part of

the costs of installing your solar electric system was taken from

an on-going Government programme of research and

development research aimed at cost reduction?

Yes No

## Savings

**20** How do you pay for your electricity?

By monthly direct debit

By quarterly bill by cheque, cash or transfer

By card meter

By quarterly direct debit

Other (please state) \_\_\_\_\_

**21** Are your electricity bills lower now that you have a solar electric system?

Yes No Not sure

**22** Do you know how much money the solar electric system has saved you per year?

Yes No

\*If yes, how much? \_\_\_\_\_

\*If no, please estimate how much you think it might save you \_\_\_\_\_

\*Please give your answers either in pounds or as a proportion of your electricity bill

**23** Does your electricity supplier pay you for any surplus electricity that you export?

Yes No

If yes, how much are you paid? \_\_\_\_\_  
(in pence/kilowatt-hour [p/kWh])

## Environmental savings

**24** Is your solar electric system saving greenhouse gas emissions?

Yes No Not sure

**25** Do you know how much carbon dioxide (CO<sub>2</sub>) is saved each year?

No, not sure how to calculate it

No, not interested

Yes

If yes, how much? \_\_\_\_\_

## How it looks

**26** Do you think the solar electric system has enhanced the appearance of the house or made it worse?

Enhanced it

Made it worse

Made no difference

## What others think

**27** Do neighbours or visitors comment on the panels on the roof without it being mentioned to them?

Yes No

**28** If you talk with neighbours or visitors about your solar electric system are comments predominantly positive or negative?

Positive

Negative

Don't talk about it

## No one comments

If you can recall any specific comments, either positive or negative, please add them here

\_\_\_\_\_  
\_\_\_\_\_  
\_\_\_\_\_

**29** Have you told your friends/relatives about your solar electric system?

Yes No

**30** Would you recommend a solar electric system to a friend/relative?

Yes No

If no, why not? \_\_\_\_\_

## Problems

**30** Have you had any problems with the system?

Yes No

If yes, tick which components have given you problems and provide a brief description of the problem if known.

Problem with: Problem description

Panels/tiles \_\_\_\_\_

Inverter \_\_\_\_\_

Meter(s) \_\_\_\_\_

Monitoring \_\_\_\_\_

Vandalism \_\_\_\_\_

Theft \_\_\_\_\_

Other? (please state) \_\_\_\_\_

**31** Have you had to arrange call-outs for system repairs?

Yes No

If yes, how many? \_\_\_\_\_

**32** Was the maintenance service prompt?

Yes No

**33** Have there been any billing problems with your electricity supplier?

Yes No

If yes, please describe? \_\_\_\_\_

## Finally

**35** Which of the following best describes your feelings about having a solar electric system on your house? (tick one answer only)

I like it a lot, it looks good and is a great idea, there should

be more systems on other houses

I quite like it although I have reservations about some

aspects of it

It's OK, there are some aspects that I like about it and

some that I don't

I don't like it much, although there are one or two positive aspects

I don't like it at all and would prefer not to have it on

my roof?

**36** What aspects do you like about it? (If you want to tick more than one answer please indicate which is the most important on a scale of 1 to 5 with 1 being the most important and 5 the least)

Saves me money

Good for the environment

Visual impact

Good talking point with friends/family

Other (please state)

---

**37** What aspects do you dislike?

Visual impact

Maintenance problems

Spending tax payers money

Disturbance (ie people wanting access to my house to

view/work on the system)

Other (please state)

---

**38** Do you think the use of solar electric systems should be more widespread?

Yes No

Why/why not?

---

**39** Do you have any other comments about the system?

Please add anything further that you would like to say in the space below.

---

If you would like further information, ie more details about system operation, sales information for friends/relatives, CO<sub>2</sub> savings, please add your name and address below and let us know what information you require. We will either pass this information to you directly or tell you where you might obtain it.

---

---

---

---

---

---

---